

Specifications:

Model	Colour code curve	Bore mm	Motor output kW	Rated current A	Head max. m	Capacity max. l/min	Dry weight kg w/o cable	Max. solid handling ø mm	Pressure resistance max. m	Cable length m
80BZ41.5	1			4,0	8,5	1400	78,0		15	

Non-clog impeller allows large diameter of foreign matter with respect to discharge bore. This ensures that waste water and sewage are efficiently transferred.

ø Discharge bore mm		80mm		
Pumping Fluid	Type of Fluid	Municipal sewage		
	Temperature	0-40°C		
Pump	Components	Impeller	Non-clog impeller	
		Shaft Seal	Double mechanical seal	
		Bearings	Shielded ball bearings	
	Material	Impeller	Grey iron casting EN-GJL-200	
		Casing	Grey iron casting EN-GJL-200	
		Suction Plate	Grey iron casting EN-GJL-200	
		Shaft Seal	Silicon carbide in oil bath	
Motor	Type, Poles		Induction motor, 4 poles, IP68	
	Insulation		Insulation class F	
	Motor Protector (built-in)		Circle thermal cut-out	
	Lubrication		Turbine oil (ISO VG32)	
	Phase / Voltage		3-phase / 400V / 50Hz / d.o.l.	
	Material	Casing	Grey iron casting EN-GJL-150	
		Shaft	Stainless steel EN-X30Cr13	
Cable		Rubber, NSSHÖU		
Discharge Connection		Inside thread, JIS10K flange		
Optional Accessories		Guide rail fitting "TOS" (guide support, duck foot bend, lifting chain) / Bend and stand set for free standing types		

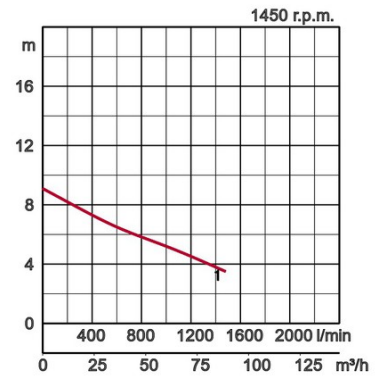

Dimensions in mm:

Model	A	A1	B	D	D1	H	W1
80BZ41.5	523	302	303	273	133	631	235

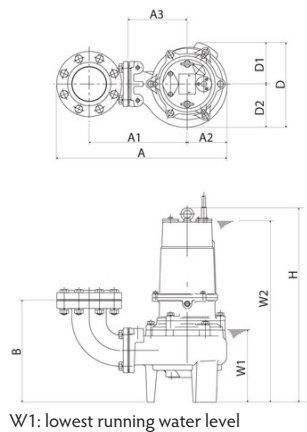

Please mind: discharge bend, duck foot bend and stand set are accessories and must be ordered separately