



Submersible Pumps for Industry and Sewerage

Tsurumi products are distributed worldwide and renowned for their advanced technological design. For professional use.



A | Tsurumi Stuffing Box - absolutely watertight



The stuffing box is located at the cable entry section and takes the part of sealing off water. As the cable conductors consist of twisted wires, water may penetrate into the motor by the capillary phenomenon when cable sheath or insulation is damaged or when the end of the cable is submerged. The construction is such that a certain part of the insulation of each conductor is peeled and filled with rubber or epoxy resin for the complete sealing.

B | Built-in motor protection

Located directly above the motor windings, a snap-action self-resetting bi-metal device cuts off voltage from all three phase windings simultaneously if the current is too large in one, two or all three windings, or if the windings get too hot.

Tsurumi enables measurement of winding resistance and insulation from the far end of the cable, without ever removing the cover from the motor in the field.

C | Ball bearings of highest quality

Due to the high quality of the shaft and the bear rings all pumps can be run horizontally when entirely submerged.

D | Double mechanical SiC seal in oil bath

All Tsurumi pumps dispose of a double mechanical seal for increased durability: The double inside mechanical seals of all our sewage pumps have sealing rings of Silicon Carbide, no other material has greater hardness. Resistance to temperature fluctuation and corrosion is also the best available.

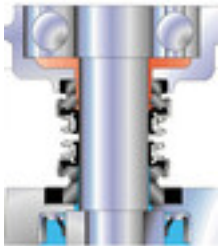





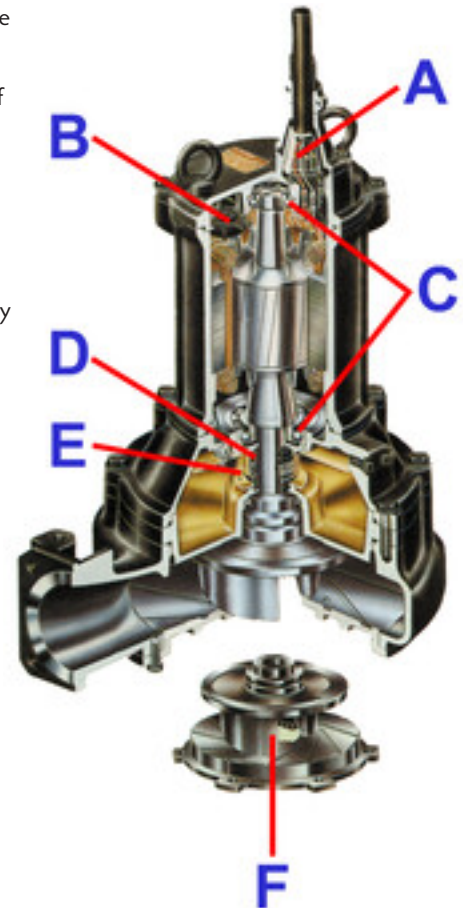
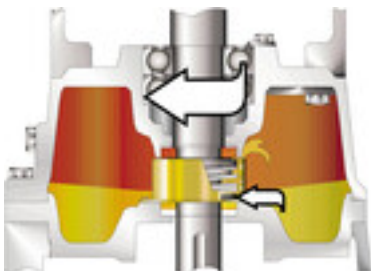











E | Oil Lifter

A special guide vane is attached inside the oil chamber. With the motor rotation oil is pumped up. Therefore even at low oil level lubrication and cooling of the mechanical seal is secured.



F | Impeller

A variety of types are available, depending on applications, i.e. open type, closed type, non-clog type and vortex type.

| Type | Model | Bore mm | Power output kW | Poles | Impeller | Motor protector (built-in) | Level sensor | Guide rail fitting | Page |
|---------------------|-------|----------|-----------------|-------|---|----------------------------|--------------|--------------------|------|
| Sewage | POMA | 50 | 0,15 | 2 |  | Vortex | ○ | ○ | 4 |
| | OM | 32 | 0,15 | 2 |  | Vortex | ○ | ○ | 5 |
| | PNI | 50 | 0,4 0,75 | 2 |  | Vortex | ○ | ○ | 6 |
| | PU | 50 80 | 0,4 - 1,5 | 2 |  | Vortex | ○ | ○ | 7 |
| | UT | 40 50 | 0,75 - 0,25 | 2 |  | Vortex | ○ | ○ | 8 |
| | U | 40 - 80 | 0,75 - 3,7 | 2 |  | Vortex | ○ | ○ | 9 |
| | UZ | 50 - 100 | 1,5 - 11 | 4 |  | Vortex | ○ | ○ | 10 |
| | B | 50 - 150 | 0,75 - 15 | 2 4 |  | Canal | ○ | ○ | 11 |
| | C | 50 - 100 | 0,75 - 11 | 2 4 |  | Canal Cutter mechanism | ○ | ○ | 12 |
| | BZ | 80 100 | 1,5 - 11 | 4 |  | Canal | ○ | ○ | 13 |
| Scum Collection | FSP | 50 | 0,75 0,4 | 2 |  | Canal | ○ | ○ | 14 |
| Corrosion Resistant | SFQ | 50 80 | 0,75 - 11 | 2 |  | Vortex | ○ | ○ | 15 |
| | SQ | 50 | 0,75 0,4 | 2 |  | Vortex | ○ | ○ | 16 |
| Salt Water | TM | 50 | 0,75 0,4 | 2 |  | Vortex | ○ | ○ | 17 |
| Aeration | TRN | | 0,75 - 40 | 2 4 |  | Vortex | ○ | ○ | 18 |
| | BER | | 0,75 - 5,5 | 2 4 |  | Canal | ○ | ○ | 19 |

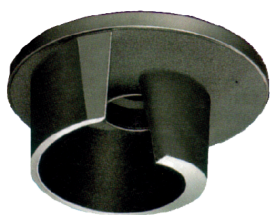

Non-clog impeller

An impeller used in centrifugal pumps. This impeller is characteristic for preventing internal clogging by solids in the pumped liquid.



Non-clog impeller (shrouded type)

An impeller having a wide channel extending from inlet to exit, which prevents internal clogging by solids sucked in via the inlet.

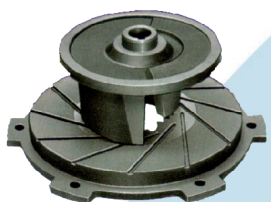

Non-clog impeller (with cutter mechanism)

A "cutter mechanism" is provided by the combined action of a carbide blade integrated into a non-clog impeller and the saw-shaped inner surface of a suction cover.



Non-clog impeller BZ-series

Non-clog impeller allows large diameter of foreign matter with respect to discharge bore.

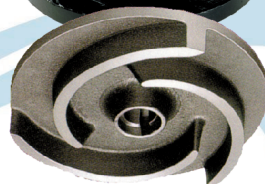

Vortex impeller (open type)

The semi-open impeller blade rotates about 0,5mm above the wear plate, clearing themselves of possible settled matter.



Vortex impeller

This impeller is used mainly to avoid clogging or wear by large or stringy solids in the water. It accelerates part of the water to great speed, and this speed is used to smoothly move all the water from inlet to outlet.



Specifications:

| Model | Colour code curve | Bore mm | Power output kW | Phases | r.p.m. | Head max. m | Capacity max. l/min | Starting method | Dry weight kg without cable | Impeller passage mm |
|-------|-------------------|---------|-----------------|--------|--------|-------------|---------------------|-----------------|-----------------------------|---------------------|
| POMA | 1 | 50 | 0,15 | 1 | 2850 | 5,25 | 205 | condensor | 5,5 | 35 |

Pump casing, head cover and impeller made of fibre-reinforced plastic (FRP). 35mm impeller passage.



| | | | |
|----------------------|----------------------------|-----------------------------|------------------------------------|
| ø Discharge bore mm | | 50mm | |
| Pumping Fluid | Temperature | 0-40°C | |
| | Type of Fluid | Domestic sewage | |
| Pump | Components | Impeller | Vortex impeller |
| | | Shaft Seal | Double mechanical seal |
| | | Bearings | Shielded ball bearings |
| | Material | Impeller | Glass fibre reinforced plastic |
| | | Upper casing | Glass fibre reinforced plastic |
| | | Lower casing | Plastic |
| | Shaft Seal | Silicon carbide in oil bath | |
| Motor | Insulation | | Insulation class E |
| | Type, Poles | | Induction motor, 2 poles, IP68 |
| | Motor Protector (built-in) | | Circle thermal cut-out |
| | Lubrication | | Turbine oil (ISO VG32) |
| | Phase / Voltage | | Single phase 230V / 110V / 50Hz |
| | Material | Casing | Stainless steel EN-X5CrNi18-10 |
| | | Shaft | Stainless steel EN-X5CrNiMo17-12-2 |
| Cable | | Rubber, 10m H07RN8-F | |
| Discharge Connection | | Inside thread, flange | |

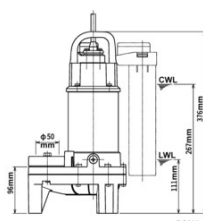
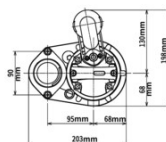
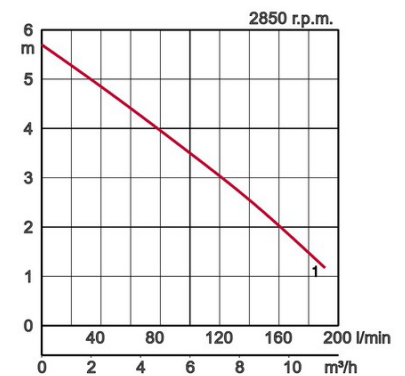

W1: lowest running water level



Specifications:

| Model | Colour code curve | Bore mm | Power output kW | Phases | r.p.m. | Head max. m | Capacity max. l/min | Starting method | Dry weight kg without cable | Impeller passage mm | Cable m |
|-------|---|---------|-----------------|--------|--------|-------------|---------------------|-----------------|-----------------------------|---------------------|---------|
| OM |  1 | 32 | 0,15 | 1 | 2850 | 7,5 | 185 | condensor | 5,1 | 10 | 10 |
| OMA | | 32 | 0,15 | 1 | 2850 | 7,5 | 185 | condensor | 5,3 | 10 | 10 |

Pump casing, head cover and impeller made of fibre-reinforced plastic (FRP).
Model OMA with level control.



| | | | |
|----------------------|----------------------------|------------------------------------|---------------------------------|
| ø Discharge bore mm | | 32mm | |
| Pumping Fluid | Temperature | 0-40°C | |
| | Type of Fluid | Domestic sewage | |
| Pump | Components | Impeller | Vortex impeller |
| | | Shaft Seal | Double mechanical seal |
| | | Bearings | Shielded ball bearings |
| | Material | Impeller | Glass fibre reinforced plastic |
| | | Upper casing | Glass fibre reinforced plastic |
| | | Lower casing | Plastic |
| | Shaft Seal | Silicon carbide in oil bath | |
| Motor | Type, Poles | | Induction motor, 2 poles, IP68 |
| | Insulation | | Insulation class E |
| | Phase / Voltage | | Single phase 230V / 110V / 50Hz |
| | Motor Protector (built-in) | | Circle thermal cut-out |
| | Lubrication | | Turbine oil (ISO VG32) |
| | Material | Casing | Stainless steel EN-X5CrNi18-10 |
| Shaft | | Stainless steel EN-X5CrNiMo17-12-2 | |
| Cable | | Rubber, 10m H07RN8-F | |
| Discharge Connection | | Inside thread, flange | |

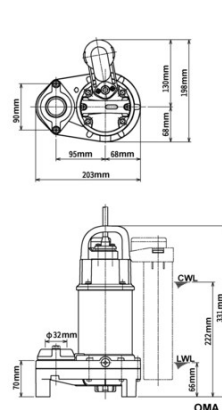
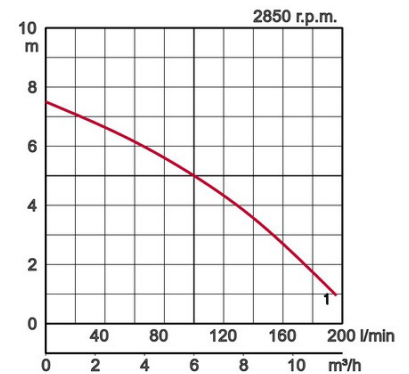

OMA

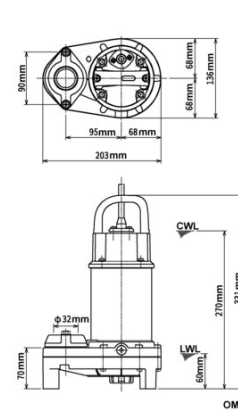

OM

W1: lowest running water level



Specifications:

| Model | Colour code curve | Bore mm | Power output kW | Phases | r.p.m. | Head max. m | Capacity max. l/min | Starting method | Dry weight kg without cable | Impeller passage mm |
|------------|-------------------|---------|-----------------|--------|--------|-------------|---------------------|-----------------|-----------------------------|---------------------|
| 50PNI2.4S | ● 1 | 50 | 0,4 | 1 | 2850 | 12,0 | 280 | condensator | 7,4 | 10 |
| 50PNI2.75S | ● 2 | 50 | 0,75 | 1 | 2850 | 15,8 | 330 | condensator | 9,5 | 10 |

Multi-purpose pump with vortex impeller.

Adjustable Float Switch - start and stop level can be adjusted, built-in auto-Manual selector Switch.



| | | | |
|----------------------|----------------------------|--|---|
| ø Discharge bore mm | | 50mm | |
| Pumping Fluid | Temperature | 0-40°C | |
| | Type of Fluid | Municipal sewage, water with solids | |
| Pump | Components | Impeller | Vortex impeller |
| | | Shaft Seal | Double mechanical seal |
| | | Bearings | Shielded ball bearings |
| | Material | Impeller | Glass fibre reinforced plastic |
| | | Upper casing | Glass fibre reinforced plastic |
| | | Lower casing | Plastic |
| | Shaft Seal | Silicon carbide in oil bath | |
| Motor | Type, Poles | | Induction motor, 2 poles, IP68 |
| | Insulation | | Insulation class E |
| | Phase / Voltage | | Single phase 230V / 50Hz |
| | Motor Protector (built-in) | | Miniature protector, Circle thermal cut-out |
| | Lubrication | | Turbine oil (ISO VG32) |
| | Material | Casing | Stainless steel EN-X5CrNi18-10 |
| Shaft | | Stainless steel EN-X6Cr13 | |
| Cable | | Rubber, 10m H07RN8-F | |
| Discharge Connection | | Inside thread, flange | |
| Optional Accessories | | Guide rail fitting "TOK" for small pumps | |

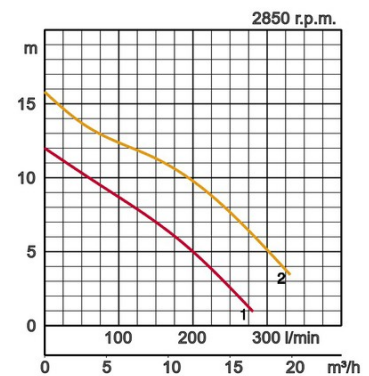

| Model | A | A1 | A2 | B | D | D1 | D2 | H | W1 | W2 |
|------------|-----|-----|----|-----|-----|----|-----|-----|-----|-----|
| 50PNI2.4S | 241 | 120 | 81 | 102 | 246 | 76 | 170 | 360 | 110 | 325 |
| 50PNI2.75S | 241 | 120 | 81 | 102 | 246 | 76 | 170 | 380 | 110 | 345 |

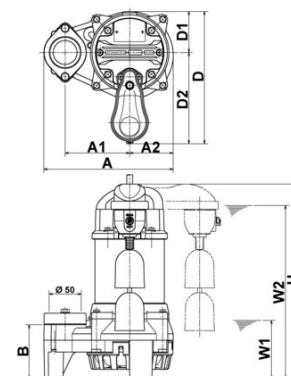

W1: lowest running water level



Specifications:

| | Model | | Colour code curve | Bore mm | Power output kW | Phases | r.p.m. | Head max. m | Capacity max. l/min | Starting method | Dry weight kg without cable | | Impeller passage mm |
|--------|---------------|-------------------------|-------------------|---------|-----------------|--------|--------|-------------|---------------------|-----------------|-----------------------------|-------------------------|---------------------|
| | free standing | with guide rail fitting | | | | | | | | | free standing | with guide rail fitting | |
| manual | 50PU2.25 | optional | ● 1 | 50 | 0,25 | 3 | 2850 | 6,6 | 210 | direct | 6,1 | - | 35 |
| | 50PU2.4 | optional | ● 2 | 50 | 0,4 | 3 | 2850 | 9,6 | 270 | direct | 7,0 | - | 35 |
| | 50PU2.4S | optional | | 50 | 0,4 | 1 | 2850 | 9,6 | 270 | condensor | 7,1 | - | 35 |
| | 50PU2.75 | optional | ● 3 | 50 | 0,75 | 3 | 2850 | 12,5 | 360 | direct | 8,3 | - | 35 |
| | 50PU2.75S | optional | | 50 | 0,75 | 1 | 2850 | 12,5 | 360 | condensor | 8,9 | - | 35 |
| autom. | 80PU21.5 | optional | ● 4 | 80 | 1,5 | 3 | 2850 | 16,0 | 800 | direct | 15,8 | - | 46 |
| | 50PUA2.4 | optional | | 50 | 0,4 | 3 | 2850 | 9,6 | 270 | direct | 7,5 | - | 35 |
| | 50PUA2.4S | optional | | 50 | 0,4 | 1 | 2850 | 9,6 | 270 | condensor | 7,7 | - | 35 |
| | 50PUA2.75 | optional | | 50 | 0,75 | 3 | 2850 | 12,5 | 360 | direct | 8,9 | - | 35 |
| | 50PUA2.75S | optional | | 50 | 0,75 | 1 | 2850 | 12,5 | 360 | condensor | 9,5 | - | 35 |



Light and solid - Guide rail fitting available for all models.

| | | | |
|----------------------|-----------------------------|--|--|
| Discharge bore mm | | 50mm, 80mm | |
| Pumping Fluid | Type of Fluid | Municipal sewage, water with solids | |
| | Temperature | 0-40°C | |
| Pump | Components | Impeller | Vortex impeller |
| | | Shaft Seal | Double mechanical seal |
| | | Bearings | Shielded ball bearings |
| | Material | Impeller | Glass fibre reinforced plastic |
| | | Upper casing | Glass fibre reinforced plastic |
| | | Lower casing | Plastic |
| Shaft Seal | Silicon carbide in oil bath | | |
| Motor | Type, Poles | | Induction motor, 2 poles, IP68 |
| | Insulation | | Insulation class E |
| | Phase / Voltage | | 3-phase / 400V / 50Hz / d.o.l., Single phase 230V / 50Hz |
| | Motor Protector (built-in) | | Circle thermal cut-out |
| | Lubrication | | Turbine oil (ISO VG32) |
| | Material | Casing | Stainless steel EN-X5CrNi18-10 |
| Shaft | | Stainless steel EN-X5CrNi18-10 | |
| Cable | | Rubber, 10m H07RN8-F | |
| Discharge Connection | | Inside thread, flange | |
| Optional Accessories | | Guide rail fitting "TOK" for small pumps | |

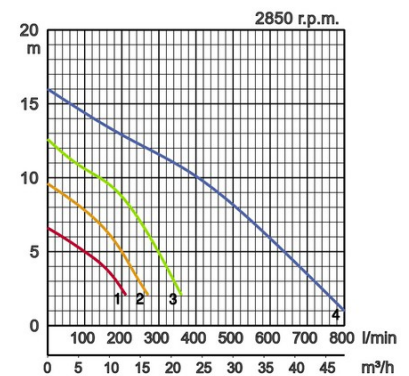

| Model | A | A1 | A2 | B | D | D1 | D2 | FL1 | FL2 | H | W1 | W2 |
|------------|-----|-----|----|-----|-----|----|-----|-----|-----|-----|-----|-----|
| 50PU2.25 | 236 | 115 | 81 | 102 | 162 | 76 | 86 | - | - | 349 | 110 | 310 |
| 50PU2.4 | 236 | 115 | 81 | 102 | 162 | 76 | 86 | - | - | 360 | 110 | 325 |
| 50PU2.4S | 236 | 115 | 81 | 102 | 162 | 76 | 86 | - | - | 360 | 110 | 325 |
| 50PU2.75 | 236 | 115 | 81 | 102 | 162 | 76 | 86 | - | - | 374 | 110 | 335 |
| 50PU2.75S | 236 | 115 | 81 | 102 | 162 | 76 | 86 | - | - | 374 | 110 | 335 |
| 80PU21.5 | 295 | 145 | 99 | 130 | 196 | 92 | 104 | - | - | 475 | 150 | 427 |
| 50PUA2.4 | 236 | 115 | 81 | 102 | 173 | 76 | 97 | 115 | 607 | 374 | - | - |
| 50PUA2.4S | 236 | 115 | 81 | 102 | 173 | 76 | 97 | 115 | 607 | 374 | - | - |
| 50PUA2.75 | 236 | 115 | 81 | 102 | 173 | 76 | 97 | 115 | 621 | 388 | - | - |
| 50PUA2.75S | 236 | 115 | 81 | 102 | 173 | 76 | 97 | 115 | 621 | 388 | - | - |

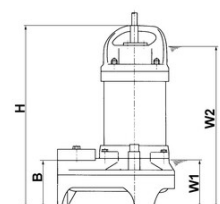
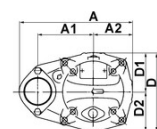
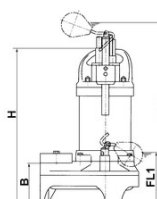
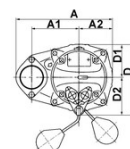

50PUA2.4S
50PUA2.4
50PUA2.75
50PUA2.75S

50PU2.25
50PU2.4S
50PU2.4
50PU2.75
80PU21.5
50PU2.75S

W1: lowest running water level



Specifications:

| Model | | Colour code curve | Bore mm | Power output kW | Phases | r.p.m. | Head max. m | Capacity max. l/min | Starting method | Dry weight kg without cable | | Impeller passage mm |
|---------------|-------------------------|-------------------|---------|-----------------|--------|--------|-------------|---------------------|-----------------|-----------------------------|-------------------------|---------------------|
| free standing | with guide rail fitting | | | | | | | | | free standing | with guide rail fitting | |
| 40UT2.25 | optional | 1 | 40 | 0,25 | 3 | 2850 | 6,5 | 230 | direct | 13,5 | - | 35 |
| 40UT2.25S | optional | | 40 | 0,25 | 1 | 2850 | 6,5 | 230 | direct | 14,0 | - | 35 |
| 50UT2.4 | optional | 2 | 50 | 0,4 | 3 | 2850 | 9,0 | 270 | direct | 13,5 | - | 35 |
| 50UT2.4S | optional | | 50 | 0,4 | 1 | 2850 | 9,0 | 270 | direct | 14,0 | - | 35 |
| 50UT2.75 | optional | 3 | 50 | 0,75 | 3 | 2850 | 12,5 | 440 | direct | 16,0 | - | 35 |
| 50UT2.75S | optional | | 50 | 0,75 | 1 | 2850 | 12,5 | 440 | direct | 17,0 | - | 35 |



Vortex impeller with wide pump casing, preventing clogging by solids and fibrous matter.

| | | | |
|----------------------|----------------------------|--|------------------------------|
| Discharge bore mm | | 40mm, 50mm | |
| Pumping Fluid | Temperature | 0-40°C | |
| | Type of Fluid | Municipal sewage, water with solids | |
| Pump | Components | Impeller | Vortex impeller |
| | | Shaft Seal | Double mechanical seal |
| | | Bearings | Shielded ball bearings |
| | Material | Impeller | Plastic |
| | | Casing | Grey iron casting EN-GJL-200 |
| | | Shaft Seal | Silicon carbide in oil bath |
| Motor | Type, Poles | Induction motor, 2 poles, IP68 | |
| | Insulation | Insulation class E | |
| | Phase / Voltage | Single phase 230V / 50Hz, 3-phase / 400V / 50Hz / d.o.l. | |
| | Motor Protector (built-in) | Circle thermal cut-out | |
| | Lubrication | Turbine oil (ISO VG32) | |
| | Material | Casing | Grey iron casting EN-GJL-150 |
| Shaft | | Stainless steel EN-X6Cr13 | |
| Cable | | Rubber, H07RN-F | |
| Discharge Connection | | Inside thread, JIS10K flange | |
| Optional Accessories | | Guide rail fitting "TOK" for small pumps | |

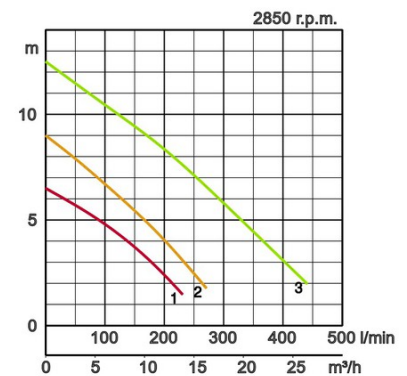

| Model | A | A4 | B | D | FL1 | FL2 | H | W1 | W2 |
|-----------|-----|-----|-----|-----|-----|-----|-----|-----|-----|
| 40UT2.25 | 239 | 205 | 101 | 161 | - | - | 350 | 110 | 300 |
| 40UT2.25S | 239 | 205 | 101 | 161 | - | - | 350 | 110 | 300 |
| 50UT2.4 | 242 | 205 | 101 | 161 | - | - | 350 | 110 | 300 |
| 50UT2.4S | 242 | 205 | 101 | 161 | - | - | 350 | 110 | 300 |
| 50UT2.75 | 242 | 205 | 101 | 161 | - | - | 406 | 110 | 350 |
| 50UT2.75S | 242 | 205 | 101 | 161 | - | - | 406 | 110 | 350 |

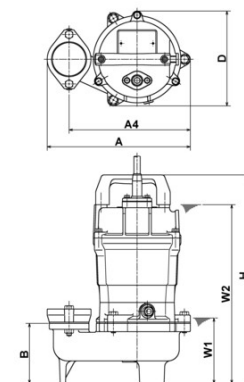

W1: lowest running water level



Specifications:

| | Model | | Colour code curve | Bore mm | Power output kW | Phases | r.p.m. | Head max. m | Capacity max. l/min | Starting method | Dry weight kg without cable | | Impeller passage mm |
|--------|---------------|-------------------------|-------------------|---------|-----------------|--------|--------|-------------|---------------------|-----------------|-----------------------------|-------------------------|---------------------|
| | free standing | with guide rail fitting | | | | | | | | | free standing | with guide rail fitting | |
| manual | 80U21.5 | TOS80U21.5 | ● 1 | 80 | 1,5 | 3 | 2850 | 16,5 | 600 | direct | 40,0 | 36,0 | 46 |
| | 80U22.2 | TOS80U22.2 | ● 2 | 80 | 2,2 | 3 | 2850 | 19,0 | 800 | direct | 55,0 | 51,0 | 56 |
| | 80U23.7 | TOS80U23.7 | ● 3 | 80 | 3,7 | 3 | 2850 | 23,5 | 1030 | direct | 62,0 | 58,0 | 56 |

Vortex impeller with wide pump casing, preventing clogging by solids and fibrous matter.



| | | | |
|----------------------|----------------------------|--|--------------------------------|
| ø Discharge bore mm | | 80mm | |
| Pumping Fluid | Type of Fluid | Municipal sewage, water with solids | |
| | Temperature | 0-40°C | |
| Pump | Components | Impeller | Vortex impeller |
| | | Shaft Seal | Double mechanical seal |
| | | Bearings | Shielded ball bearings |
| | Material | Impeller | Grey iron casting EN-GJL-200 |
| Casing | | Grey iron casting EN-GJL-200 | |
| Shaft Seal | | Silicon carbide in oil bath | |
| Motor | Motor Protector (built-in) | | Circle thermal cut-out |
| | Lubrication | | Turbine oil (ISO VG32) |
| | Phase / Voltage | | 3-phase / 400V / 50Hz / d.o.l. |
| | Type, Poles | | Induction motor, 2 poles, IP68 |
| | Insulation | | Insulation class F |
| | Material | Casing | Grey iron casting EN-GJL-150 |
| | | Shaft | Stainless steel EN-X30Cr13 |
| Cable | | Rubber, NSSHÖU | |
| Discharge Connection | | Inside thread, JIS10K flange | |
| Optional Accessories | | Guide rail fitting "TOS" (guide support, duck foot bend, lifting chain) / Bend and stand set for free standing types | |

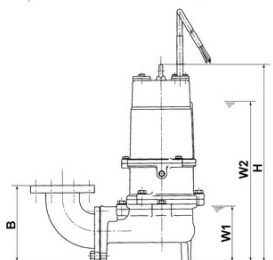
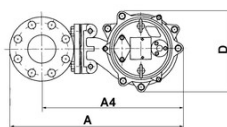
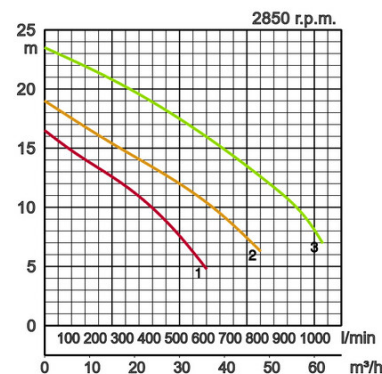

W1: lowest running water level

| Model | A | A4 | B | D | H | W1 | W2 |
|---------|-----|-----|-----|-----|-----|-----|-----|
| 80U21.5 | 420 | 366 | 173 | 200 | 501 | 135 | 430 |
| 80U22.2 | 502 | 410 | 225 | 240 | 562 | 160 | 490 |
| 80U23.7 | 502 | 410 | 226 | 234 | 565 | 160 | 520 |



Specifications:

| Model | | Colour code curve | Bore mm | Power output kW | Phases | r.p.m. | Head max. m | Capacity max. l/min | Starting method | Dry weight kg without cable | | Impeller passage mm |
|---------------|-------------------------|-------------------|---------|-----------------|--------|--------|-------------|---------------------|-----------------|-----------------------------|-------------------------|---------------------|
| free standing | with guide rail fitting | | | | | | | | | free standing | with guide rail fitting | |
| 50UZ41.5 | TOS50UZ41.5 | 1 | 50 | 1,5 | 3 | 1450 | 10,2 | 644 | direct | 52,0 | 50,0 | 50 |
| 80UZ41.5 | TOS80UZ41.5 | 2 | 80 | 1,5 | 3 | 1450 | 7,5 | 1120 | direct | 66,0 | 56,0 | 80 |
| 80UZ42.2 | TOS80UZ42.2 | 3 | 80 | 2,2 | 3 | 1450 | 8,8 | 1395 | direct | 66,0 | 57,0 | 80 |
| 80UZ43.7 | TOS80UZ43.7 | 4 | 80 | 3,7 | 3 | 1450 | 12,7 | 1520 | direct | 72,0 | 63,0 | 80 |
| 100UZ43.7 | TOS100UZ43.7 | 5 | 100 | 3,7 | 3 | 1450 | 10,1 | 1890 | direct | 79,0 | 70,0 | 100 |
| 80UZ45.5 | TOS80UZ45.5 | 6 | 80 | 5,5 | 3 | 1450 | 15,0 | 1900 | direct | 129,0 | 125,0 | 80 |
| 100UZ45.5 | TOS100UZ45.5 | 7 | 100 | 5,5 | 3 | 1450 | 13,2 | 2360 | direct | 145,0 | 134,0 | 100 |
| 80UZ47.5 | TOS80UZ47.5 | 8 | 80 | 7,5 | 3 | 1450 | 19,0 | 1900 | direct | 142,0 | 137,0 | 80 |
| 100UZ47.5 | TOS100UZ47.5 | 9 | 100 | 7,5 | 3 | 1450 | 15,6 | 2500 | direct | 158,0 | 147,0 | 100 |
| 100UZ411 | TOS100UZ411 | 10 | 100 | 11 | 3 | 1450 | 19,0 | 2600 | star/delta | 191,0 | 180,0 | 100 |



Vortex impeller with wide pump casing, 4-pole motor, no clogging.

| | | | |
|----------------------|----------------------------|--|--|
| Discharge bore mm | | 50mm, 80mm, 100mm | |
| Pumping Fluid | Type of Fluid | Municipal sewage, water with solids | |
| | Temperature | 0-40°C | |
| Pump | Components | Impeller | Vortex impeller |
| | | Shaft Seal | Double mechanical seal |
| | | Bearings | Shielded ball bearings |
| | Material | Impeller | Grey iron casting EN-GJL-200 |
| Casing | | Grey iron casting EN-GJL-200 | |
| Shaft Seal | | Silicon carbide in oil bath | |
| Motor | Phase / Voltage | | 3-phase / 400V / 50Hz / d.o.l., 3-phase / 400V / 50Hz / s.d. |
| | Motor Protector (built-in) | | Circle thermal cut-out |
| | Lubrication | | Turbine oil (ISO VG32) |
| | Insulation | | Insulation class E, Insulation class F |
| | Type, Poles | | Induction motor, 4 poles, IP68 |
| | Material | Casing | Grey iron casting EN-GJL-150, Grey iron casting EN-GJL-200 |
| Shaft | | Stainless steel EN-X30Cr13 | |
| Cable | | Rubber, NSSHÖU | |
| Discharge Connection | | Inside thread, JIS10K flange | |
| Optional Accessories | | Guide rail fitting "TOS" (guide support, duck foot bend, lifting chain) / Bend and stand set for free standing types | |

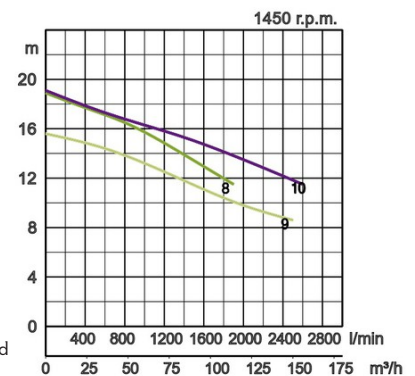
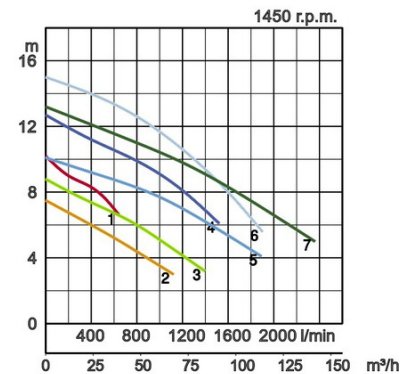

| Model | A | A1 | A2 | A3 | B | D | D1 | D2 | H | W1 | W2 |
|-----------|-----|-----|-----|-----|-----|-----|-----|-----|------|-----|-----|
| 50UZ41.5 | 405 | 228 | 123 | 142 | 179 | 250 | 110 | 140 | 566 | 170 | 525 |
| 80UZ41.5 | 531 | 312 | 126 | 200 | 285 | 261 | 128 | 133 | 637 | 240 | 595 |
| 80UZ42.2 | 531 | 312 | 126 | 200 | 285 | 261 | 128 | 133 | 637 | 240 | 595 |
| 80UZ43.7 | 557 | 312 | 153 | 200 | 285 | 291 | 141 | 150 | 688 | 240 | 645 |
| 100UZ43.7 | 628 | 368 | 155 | 240 | 330 | 314 | 149 | 165 | 737 | 290 | 695 |
| 80UZ45.5 | 595 | 342 | 160 | 230 | 290 | 358 | 179 | 179 | 899 | 280 | 770 |
| 100UZ45.5 | 652 | 387 | 160 | 260 | 335 | 358 | 179 | 179 | 939 | 320 | 810 |
| 80UZ47.5 | 595 | 342 | 160 | 230 | 290 | 358 | 179 | 179 | 920 | 280 | 790 |
| 100UZ47.5 | 652 | 387 | 160 | 260 | 335 | 358 | 179 | 179 | 960 | 320 | 830 |
| 100UZ411 | 660 | 387 | 168 | 230 | 337 | 358 | 179 | 179 | 1021 | 335 | 865 |

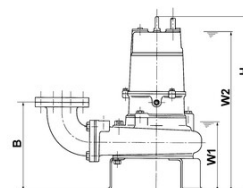
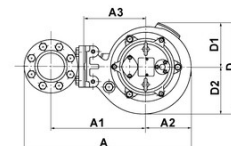

W1: lowest running water level



Specifications:

| Model | | Colour code curve | Bore mm | Power output kW | Phases | r.p.m. | Head max. m | Capacity max. l/min | Starting method | Dry weight kg without cable | | Impeller passage mm |
|---------------|-------------------------|-------------------|---------|-----------------|--------|--------|-------------|---------------------|-----------------|-----------------------------|-------------------------|---------------------|
| free standing | with guide rail fitting | | | | | | | | | free standing | with guide rail fitting | |
| 50B2.4 | TOS50B2.4 | 1 | 50 | 0,4 | 3 | 2850 | 9,0 | 260 | direct | 23,0 | 22,0 | 19 |
| 50B2.75 | TOS50B2.75 | 2 | 50 | 0,75 | 3 | 2850 | 12,0 | 435 | direct | 25,0 | 24,0 | 20 |
| 50B2.75H | TOS50B2.75H | 3 | 50 | 0,75 | 3 | 2850 | 15,2 | 360 | direct | 24,0 | 23,0 | 20 |
| 80B21.5 | TOS80B21.5 | 4 | 80 | 1,5 | 3 | 2850 | 16,8 | 1000 | direct | 36,0 | 34,0 | 40 |
| 100B42.2 | TOS100B42.2 | 5 | 100 | 2,2 | 3 | 1450 | 16,0 | 1500 | direct | 70,0 | 64,0 | 45 |
| 100B43.7 | TOS100B43.7 | 6 | 100 | 3,7 | 3 | 1450 | 16,4 | 2000 | direct | 86,0 | 80,0 | 53 |
| 150B43.7 | TOS150B43.7 | 7 | 150 | 3,7 | 3 | 1450 | 7,1 | 4000 | direct | 145,0 | 80,0 | 53 |
| 100B43.7H | TOS100B43.7H | 8 | 100 | 3,7 | 3 | 1450 | 20,0 | 1180 | direct | 84,0 | 78,0 | 35 |
| 100B45.5 | TOS100B45.5 | 9 | 100 | 5,5 | 3 | 1450 | 26,0 | 2080 | direct | 147,0 | 140,0 | 40 |
| 100B47.5 | TOS100B47.5 | 10 | 100 | 7,5 | 3 | 1450 | 29,7 | 2260 | direct | 169,0 | 150,0 | 40 |
| 150B47.5L | TOS150B47.5L | 11 | 150 | 7,5 | 3 | 1450 | 13,95 | 5000 | direct | 200,0 | 175,0 | 60 |
| 150B415 | TOS150B415 | 12 | 150 | 15 | 3 | 1450 | 28,0 | 4500 | star/delta | 270,0 | 240,0 | 75 |



Sewage pump with non-clogging impeller

| | | | | |
|----------------------|--|--|--|--|
| Discharge bore mm | | 50mm, 80mm, 100mm, 150mm | | |
| Pumping Fluid | Type of Fluid | Municipal sewage | | |
| | Temperature | 0-40°C | | |
| Pump | Components | Impeller | Non-clog impeller | |
| | | Shaft Seal | Double mechanical seal | |
| | | Bearings | Shielded ball bearings | |
| | Material | Impeller | Grey iron casting EN-GJL-200 | |
| | | Casing | Grey iron casting EN-GJL-200 | |
| | | Suction Plate | Ductile iron casting EN-GJS-450-10, Grey iron casting EN-GJL-200 | |
| | Shaft Seal | Silicon carbide in oil bath | | |
| Motor | Type, Poles | Induction motor, 2 poles, IP68, 4 poles | | |
| | Insulation | Insulation class E, Insulation class F | | |
| | Phase / Voltage | 3-phase / 400V / 50Hz / d.o.l., 3-phase / 400V / 50Hz / s.d. | | |
| | Motor Protector (built-in) | Circle thermal cut-out | | |
| | Lubrication | Turbine oil (ISO VG32) | | |
| | Material | Casing | Grey iron casting EN-GJL-150, Grey iron casting EN-GJL-200 | |
| | | Shaft | Stainless steel EN-X6Cr13, Stainless steel EN-X30Cr13 | |
| Cable | | Rubber, NSSHÖU | | |
| Discharge Connection | Inside thread, JIS10K flange | | | |
| Optional Accessories | Guide rail fitting "TOS" (guide support, duck foot bend, lifting chain) / Bend and stand set for free standing types | | | |

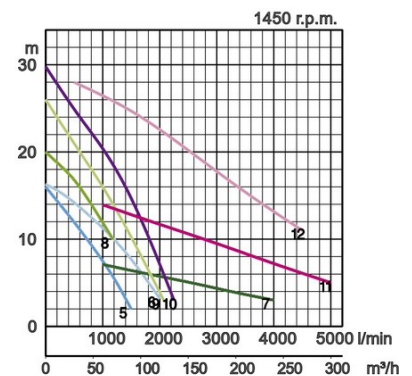
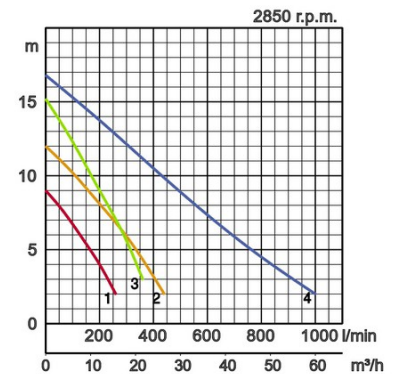

| Model | A | A1 | A2 | A3 | B | B1 | D | D1 | D2 | H | W1 | W2 |
|-----------|-----|-----|-----|-----|-----|-----|-----|-----|-----|------|-----|------|
| 50B2.4 | 347 | 208 | 85 | 120 | 181 | 155 | 224 | 112 | 112 | 443 | 140 | 340 |
| 50B2.75 | 405 | 226 | 125 | 138 | 199 | 155 | 250 | 125 | 125 | 439 | 170 | 410 |
| 50B2.75H | 405 | 226 | 125 | 138 | 199 | 155 | 250 | 125 | 125 | 415 | 145 | 385 |
| 80B21.5 | 446 | 267 | 125 | 165 | 234 | 140 | 250 | 125 | 125 | 536 | 190 | 465 |
| 100B42.2 | 569 | 322 | 154 | 210 | 303 | 210 | 331 | 164 | 167 | 616 | 225 | 570 |
| 100B43.7 | 575 | 322 | 160 | 210 | 308 | 210 | 339 | 164 | 175 | 690 | 235 | 645 |
| 150B43.7 | 871 | 503 | 228 | 320 | 515 | 280 | 486 | 232 | 254 | 875 | 450 | 830 |
| 100B43.7H | 569 | 322 | 154 | 210 | 303 | 210 | 331 | 164 | 167 | 666 | 225 | 620 |
| 100B45.5 | 687 | 388 | 194 | 260 | 372 | 210 | 400 | 197 | 203 | 824 | 335 | 700 |
| 100B47.5 | 687 | 388 | 194 | 260 | 372 | 210 | 400 | 197 | 203 | 814 | 335 | 720 |
| 150B47.5L | 871 | 503 | 228 | 320 | 515 | 280 | 486 | 232 | 254 | 1085 | 450 | 955 |
| 150B415 | 895 | 513 | 242 | 330 | 506 | 280 | 490 | 245 | 245 | 1168 | 405 | 1045 |

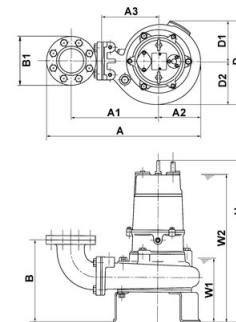

W1: lowest running water level

Canal impeller with cutter mechanism



C 3-phase
50Hz

Specifications:

| Model | | Colour code curve | Bore mm | Power output kW | Phases | r.p.m. | Head max. m | Capacity max. l/min | Starting method | Dry weight kg without cable | | Impeller passage mm |
|---------------|-------------------------|-------------------|---------|-----------------|--------|--------|-------------|---------------------|-----------------|-----------------------------|-------------------------|---------------------|
| free standing | with guide rail fitting | | | | | | | | | free standing | with guide rail fitting | |
| 50C2.75 | TOS50C2.75 | 1 | 50 | 0,75 | 3 | 2850 | 11,5 | 335 | direct | 24,0 | 23,0 | 21 |
| 80C21.5 | TOS80C21.5 | 2 | 80 | 1,5 | 3 | 2850 | 13,2 | 810 | direct | 36,0 | 34,0 | 37 |
| 100C42.2 | TOS100C42.2 | 3 | 100 | 2,2 | 3 | 1450 | 13,5 | 1100 | direct | 70,0 | 64,0 | 44 |
| 100C43.7 | TOS100C43.7 | 4 | 100 | 3,7 | 3 | 1450 | 16,0 | 1700 | direct | 86,0 | 80,0 | 60 |
| 100C45.5 | TOS100C45.5 | 5 | 100 | 5,5 | 3 | 1450 | 18,1 | 2290 | direct | 140,0 | 133,0 | 40 |
| 100C47.5 | TOS100C47.5 | 6 | 100 | 7,5 | 3 | 1450 | 23,0 | 2500 | direct | 159,0 | 152,0 | 40 |
| 100C411 | TOS100C411 | 7 | 100 | 11 | 3 | 1450 | 26,0 | 2750 | star/delta | 184,0 | 177,0 | 50 |
| 80C22.2-CR | TOS80C22.2-CR | 8 | 80 | 2,2 | 3 | 2850 | 21,0 | 750 | direct | 70,0 | 64,0 | 20x31 |
| 80C23.7-CR | TOS80C23.7-CR | 9 | 80 | 3,7 | 3 | 2850 | 29,0 | 650 | direct | 70,0 | 64,0 | 22x31 |
| 80C25.5-CR | TOS80C25.5-CR | 10 | 80 | 5,5 | 3 | 2850 | 32,0 | 1340 | direct | 125,0 | 117,0 | 29x23 |
| 80C27.5-CR | TOS80C27.5-CR | 11 | 80 | 7,5 | 3 | 2850 | 38,0 | 1000 | direct | 130,0 | 122,0 | 26x23 |
| 80C211-CR | TOS80C211-CR | 12 | 80 | 11 | 3 | 2850 | 47,0 | 1200 | star/delta | 160,0 | 152,0 | 26x25,5 |



Carbide blades in an impeller-integrated structure cut up fibrous matter.

| | | | | |
|----------------------|-----------------------------|--|---|--|
| Discharge bore mm | | 50mm, 80mm, 100mm | | |
| Pumping Fluid | Type of Fluid | Wastewater and liquid carrying waste and foreign matters | | |
| | Temperature | 0-40°C | | |
| Pump | Components | Impeller | Non-clog impeller with cutter mechanism | |
| | | Shaft Seal | Double mechanical seal | |
| | | Bearings | Shielded ball bearings | |
| | Material | Impeller | Grey iron casting EN-GJL-200 with sintered tungsten carbide alloy tip, Grauguß GG25 mit gesinterter Wolframkarbidklinge, Chromium iron casting with sintered tungsten carbide alloy tip | |
| | | Casing | Grey iron casting EN-GJL-200 | |
| | | Suction Plate | Ductile iron casting EN-GJS-700-2, Chromium iron casting | |
| Shaft Seal | Silicon carbide in oil bath | | | |
| Motor | Insulation | Insulation class E, Insulation class F | | |
| | Type, Poles | Induction motor, 2 poles, IP68, 4 poles | | |
| | Phase / Voltage | 3-phase / 400V / 50Hz / d.o.l., 3-phase / 400V / 50Hz / s.d. | | |
| | Lubrication | Turbine oil (ISO VG32) | | |
| | Motor Protector (built-in) | Circle thermal cut-out | | |
| | Material | Casing | Grey iron casting EN-GJL-150, Grey iron casting EN-GJL-200 | |
| | | Shaft | Stainless steel EN-X6Cr13, Stainless steel EN-X30Cr13 | |
| Cable | | Rubber, NSSHÖU | | |
| Discharge Connection | | Inside thread, JIS10K flange | | |
| Optional Accessories | | Guide rail fitting "TOS" (guide support, duck foot bend, lifting chain) / Bend and stand set for free standing types | | |

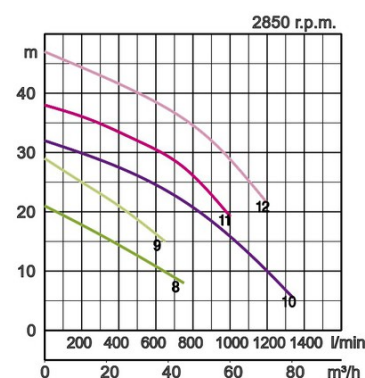
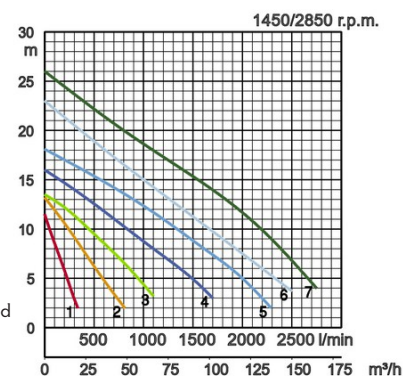

| Model | A | A4 | B | D | H | W1 | W2 |
|------------|-----|-----|-----|-----|------|-----|-----|
| 50C2.75 | 405 | 351 | 196 | 250 | 415 | 145 | 385 |
| 80C21.5 | 446 | 392 | 234 | 250 | 536 | 190 | 465 |
| 100C42.2 | 594 | 489 | 328 | 324 | 616 | 225 | 570 |
| 100C43.7 | 602 | 497 | 333 | 331 | 680 | 235 | 635 |
| 100C45.5 | 687 | 582 | 372 | 400 | 824 | 335 | 700 |
| 100C47.5 | 687 | 582 | 372 | 400 | 814 | 335 | 720 |
| 100C411 | 710 | 605 | 372 | 431 | 1000 | 300 | 840 |
| 80C22.2-CR | 519 | 427 | 292 | 260 | 613 | 180 | 565 |
| 80C23.7-CR | 519 | 427 | 291 | 260 | 613 | 180 | 565 |
| 80C25.5-CR | 615 | 522 | 320 | 345 | 879 | 225 | 745 |
| 80C27.5-CR | 615 | 522 | 320 | 345 | 879 | 225 | 745 |
| 80C211-CR | 615 | 522 | 320 | 345 | 927 | 225 | 770 |

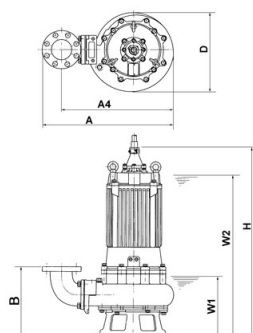

W1: lowest running water level



Specifications:

| Model | | Colour code curve | Bore mm | Power output kW | Phases | r.p.m. | Head max. m | Capacity max. l/min | Starting method | Dry weight kg without cable | | Impeller passage mm |
|---------------|-------------------------|-------------------|---------|-----------------|--------|--------|-------------|---------------------|-----------------|-----------------------------|-------------------------|---------------------|
| free standing | with guide rail fitting | | | | | | | | | free standing | with guide rail fitting | |
| 80BZ41.5 | TOS80BZ41.5 | 1 | 80 | 1,5 | 3 | 1450 | 8,5 | 1400 | direct | 78,0 | 74,0 | 80 |
| 100BZ42.2 | TOS100BZ42.2 | 2 | 100 | 2,2 | 3 | 1450 | 11,3 | 1800 | direct | 80,0 | 74,0 | 80 |
| 100BZ43.7 | TOS100BZ43.7 | 3 | 100 | 3,7 | 3 | 1450 | 14,7 | 2100 | direct | 100,0 | 94,0 | 80 |
| 100BZ45.5 | TOS100BZ45.5 | 4 | 100 | 5,5 | 3 | 1450 | 19,0 | 2085 | direct | 175,0 | 168,0 | 80 |
| 100BZ47.5 | TOS100BZ47.5 | 5 | 100 | 7,5 | 3 | 1450 | 23,6 | 2100 | direct | 194,0 | 187,0 | 80 |
| 100BZ411 | TOS100BZ411 | 6 | 100 | 11 | 3 | 1450 | 26,0 | 3575 | star/delta | 219,0 | 212,0 | 80 |
| 100BZ411H | TOS100BZ411H | 7 | 100 | 11 | 3 | 1450 | 30,0 | 2810 | star/delta | 219,0 | 212,0 | 80 |



Non-clog impeller allows large diameter of foreign matter with respect to discharge bore. This ensures that waste water and sewage are efficiently transferred.

| | | | |
|----------------------|--|--|------------------------------|
| Discharge bore mm | | 80mm, 100mm | |
| Pumping Fluid | Type of Fluid | Municipal sewage | |
| | Temperature | 0-40°C | |
| Pump | Components | Impeller | Non-clog impeller |
| | | Shaft Seal | Double mechanical seal |
| | | Bearings | Shielded ball bearings |
| | Material | Impeller | Grey iron casting EN-GJL-200 |
| | | Casing | Grey iron casting EN-GJL-200 |
| | | Suction Plate | Grey iron casting EN-GJL-200 |
| Shaft Seal | Silicon carbide in oil bath | | |
| Motor | Insulation | Insulation class F | |
| | Type, Poles | Induction motor, 4 poles, IP68 | |
| | Phase / Voltage | 3-phase / 400V / 50Hz / d.o.l., 3-phase / 400V / 50Hz / s.d. | |
| | Lubrication | Turbine oil (ISO VG32) | |
| | Motor Protector (built-in) | Circle thermal cut-out, Miniature protector | |
| | Material | Casing | Grey iron casting EN-GJL-150 |
| | | Shaft | Stainless steel EN-X30Cr13 |
| Cable | | Rubber, NSSHÖU | |
| Discharge Connection | Inside thread, JIS10K flange | | |
| Optional Accessories | Guide rail fitting "TOS" (guide support, duck foot bend, lifting chain) / Bend and stand set for free standing types | | |

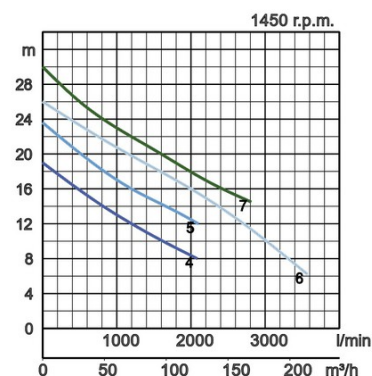
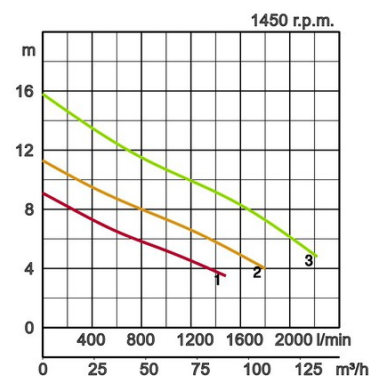

| Model | A | A1 | A2 | A3 | B | D | D1 | D2 | H | W1 | W2 |
|-----------|-----|-----|-----|-----|-----|-----|-----|-----|------|-----|-----|
| 80BZ41.5 | 523 | 302 | 129 | 190 | 303 | 273 | 133 | 140 | 631 | 235 | 590 |
| 100BZ42.2 | 551 | 317 | 129 | 190 | 328 | 273 | 133 | 140 | 631 | 235 | 590 |
| 100BZ43.7 | 584 | 327 | 153 | 200 | 328 | 289 | 139 | 150 | 681 | 235 | 640 |
| 100BZ45.5 | 716 | 407 | 204 | 280 | 380 | 421 | 205 | 216 | 925 | 305 | 790 |
| 100BZ47.5 | 716 | 407 | 204 | 280 | 380 | 421 | 205 | 216 | 946 | 305 | 820 |
| 100BZ411 | 727 | 407 | 215 | 280 | 377 | 431 | 205 | 226 | 1023 | 330 | 865 |
| 100BZ411H | 727 | 407 | 215 | 280 | 377 | 431 | 205 | 226 | 1023 | 330 | 865 |

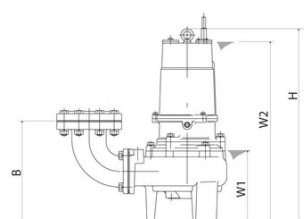
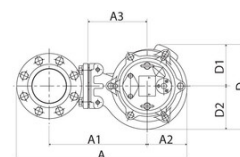

W1: lowest running water level



Specifications:

| Model | Bore mm | Power output kW | Phases | r.p.m. | Head max. m | Capacity max. l/min | Starting method | Dry weight kg without cable | Impeller passage mm |
|-------|---------|-----------------|--------|--------|-------------|---------------------|-----------------|-----------------------------|---------------------|
| 4-FSP | 50 | 0,4 | 3 | 2850 | 4,9 | 180 | direct | 36,0 | 16 |
| 8-FSP | 50 | 0,75 | 3 | 2850 | 5,3 | 255 | direct | 38,0 | 22 |

Decanting pump - The special construction of the pump ensures that only supernatant water is discharged without any entrapment of sediments.



| | | | | |
|----------------------|----------------------------|---------------------------|--------------------------------|--|
| ø Discharge bore mm | | 50mm | | |
| Pumping Fluid | Type of Fluid | Treated sewage | | |
| | Temperature | 0-40°C | | |
| Pump | Components | Impeller | Non-clog impeller | |
| | | Shaft Seal | Double mechanical seal | |
| | | Bearings | Shielded ball bearings | |
| | Material | Impeller | Grey iron casting EN-GJL-200 | |
| | | Upper casing | Grey iron casting EN-GJL-200 | |
| | | Lower casing | Grey iron casting EN-GJL-200 | |
| | | Shaft Seal | Silicon carbide in oil bath | |
| Float | Plastic | | | |
| Motor | Insulation | | Insulation class E | |
| | Type, Poles | | Induction motor, 2 poles, IP68 | |
| | Phase / Voltage | | 3-phase / 400V / 50Hz / d.o.l. | |
| | Lubrication | | Turbine oil (ISO VG32) | |
| | Motor Protector (built-in) | | Circle thermal cut-out | |
| | Material | Casing | Grey iron casting EN-GJL-150 | |
| Shaft | | Stainless steel EN-X6Cr13 | | |
| Cable | | Rubber, NSSHÖU | | |
| Discharge Connection | | Hose coupling | | |

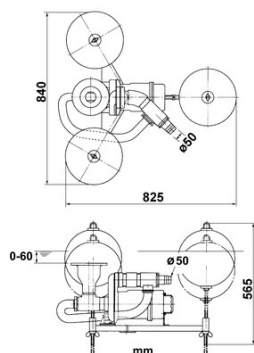
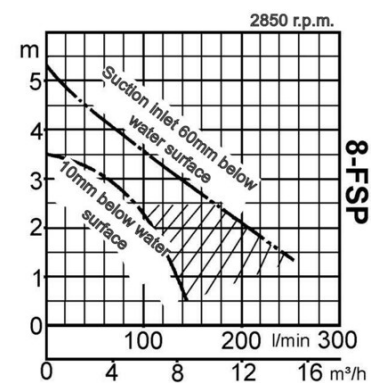
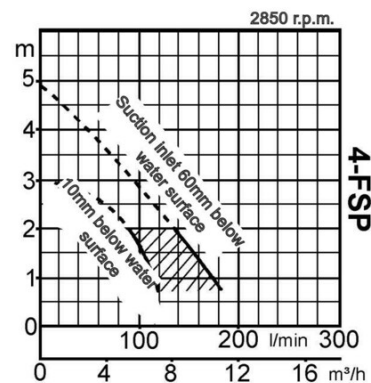



Specifications:

| Model | | Colour code curve | Bore mm | Power output kW | Phases | r.p.m. | Head max. m | Capacity max. l/min | Starting method | Dry weight kg without cable | | Impeller passage mm |
|---------------|-------------------------|-------------------|---------|-----------------|--------|--------|-------------|---------------------|-----------------|-----------------------------|-------------------------|---------------------|
| free standing | with guide rail fitting | | | | | | | | | free standing | with guide rail fitting | |
| 80SFQ21.5 | - | 1 | 80 | 1,5 | 3 | 2850 | 20,9 | 645 | direct | 36,0 | - | 6 |
| 80SFQ23.7 | - | 2 | 80 | 3,7 | 3 | 2850 | 24,6 | 1180 | direct | 52,0 | - | 15 |
| 80SFQ27.5 | TOS80SFQ27.5 | 3 | 80 | 7,5 | 3 | 2850 | 34,8 | 2000 | direct | 123,0 | 112,0 | 30 |
| 80SFQ211 | TOS80SFQ211 | 4 | 80 | 11 | 3 | 2850 | 44,0 | 1940 | star/delta | 143,0 | 132,0 | 30 |



The submersible scum skimmer FSP incorporates a jet injector (suction mechanism) for collecting scum efficiently.

| | | | | |
|----------------------|-----------------------------|--|---|--|
| Discharge bore mm | | 80mm | | |
| Pumping Fluid | Type of Fluid | Aggressive sewage | | |
| | Temperature | 0-40°C | | |
| Pump | Components | Impeller | Open type impeller | |
| | | Shaft Seal | Double mechanical seal | |
| | | Bearings | Shielded ball bearings | |
| | Material | Impeller | Stainless steel casting DIN X5CrNiMo17-12-2, Stainless steel casting DIN GX5CrNiMo19-11-2 | |
| | | Casing | Stainless steel casting DIN X5CrNiMo17-12-2, Stainless steel casting DIN GX5CrNiMo19-11-2 | |
| | | Suction Plate | Stainless steel casting DIN X5CrNiMo17-12-2, Stainless steel casting DIN GX5CrNiMo19-11-2 | |
| Shaft Seal | Silicon carbide in oil bath | | | |
| Motor | Type, Poles | Induction motor, 2 poles, IP68 | | |
| | Insulation | Insulation class F | | |
| | Lubrication | Turbine oil (ISO VG32) | | |
| | Motor Protector (built-in) | Circle thermal cut-out | | |
| | Phase / Voltage | 3-phase / 400V / 50Hz / d.o.l., 3-phase / 400V / 50Hz / s.d. | | |
| | Material | Casing | Stainless steel casting DIN X5CrNiMo17-12-2, Stainless steel casting DIN GX5CrNiMo19-11-2 | |
| Shaft | | Stainless steel EN-X5CrNiMo17-12-2 | | |
| Cable | | Rubber, NSSHÖU | | |
| Discharge Connection | | Inside thread, JIS10K flange | | |

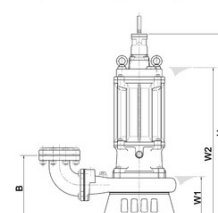
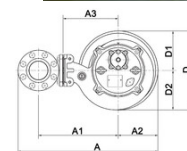
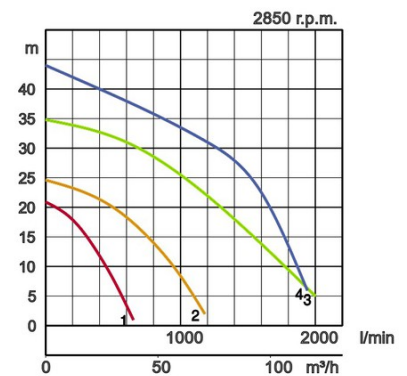

W1: lowest running water level

| Model | A | A1 | A2 | A3 | B | D | D1 | D2 | H | W1 | W2 |
|-----------|-----|-----|-----|-----|-----|-----|-----|-----|-----|-----|-----|
| 80SFQ21.5 | 329 | 165 | 110 | - | 109 | 221 | 110 | 111 | 484 | 95 | 415 |
| 80SFQ23.7 | 359 | 180 | 125 | - | 154 | 257 | 125 | 132 | 542 | 130 | 495 |
| 80SFQ27.5 | 635 | 362 | 180 | 250 | 287 | 360 | 180 | 180 | 844 | 190 | 690 |
| 80SFQ211 | 635 | 362 | 180 | 250 | 287 | 360 | 180 | 180 | 892 | 190 | 710 |



Specifications:

| Model | Colour code curve | Bore mm | Power output kW | Phases | r.p.m. | Head max. m | Capacity max. l/min | Starting method | Dry weight kg without cable | Impeller passage mm |
|----------|-------------------|---------|-----------------|--------|--------|-------------|---------------------|-----------------|-----------------------------|---------------------|
| 50SQ2.4 | 1 | 50 | 0,4 | 3 | 2850 | 10,5 | 240 | direct | 12,0 | 6 |
| 50SQ2.4S | | 50 | 0,4 | 1 | 2850 | 10,5 | 240 | condensor | 12,5 | 6 |
| 50SQ2.75 | 2 | 50 | 0,75 | 3 | 2850 | 14,5 | 300 | direct | 14,0 | 6 |

Stainless steel pump - The SFQ pump has been developed exclusively for corrosive liquids. Applying austenitic steel in all wetted parts, the SFQ pump is a highly specialised pump in terms of design and materials.



| | | | | |
|----------------------|----------------------------|--|--------------------------------|--|
| Discharge bore mm | | 50mm | | |
| Pumping Fluid | Temperature | 0-40°C | | |
| | Type of Fluid | Aggressive fluids, food industry | | |
| Pump | Components | Impeller | Vortex impeller | |
| | | Shaft Seal | Double mechanical seal | |
| | | Bearings | Shielded ball bearings | |
| | Material | Impeller | SCS13 (DIN GX5CrNi19-10) | |
| | | Casing | SCS13 (DIN GX5CrNi19-10) | |
| | | Suction Plate | Stainless steel EN-X5CrNi18-10 | |
| | Shaft Seal | Silicon carbide in oil bath | | |
| Motor | Lubrication | Turbine oil (ISO VG15) | | |
| | Motor Protector (built-in) | Circle thermal cut-out | | |
| | Phase / Voltage | Single phase 230V / 50Hz, 3-phase / 400V / 50Hz / d.o.l. | | |
| | Insulation | Insulation class E | | |
| | Type, Poles | Induction motor, 2 poles, IP68 | | |
| | Material | Casing | Stainless steel EN-X5CrNi18-10 | |
| Shaft | | Stainless steel EN-X5CrNi18-10 | | |
| Cable | | Rubber, 10m H07RN8-F, NSSHÖU | | |
| Discharge Connection | | Hose coupling | | |

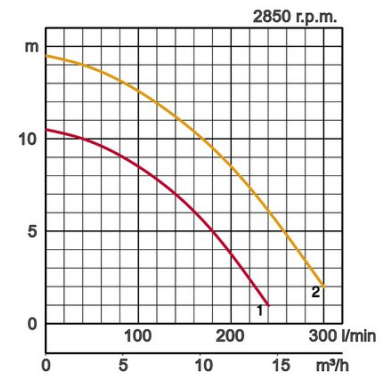

| Model | A | A1 | B | H | W1 |
|----------|-----|-----|-----|-----|----|
| 50SQ2.4 | 180 | 125 | 364 | 262 | 60 |
| 50SQ2.4S | 180 | 125 | 364 | 262 | 60 |
| 50SQ2.75 | 180 | 125 | 384 | 282 | 60 |

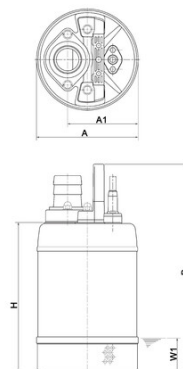

W1: lowest running water level



Specifications:

| Model | Colour code curve | Bore mm | Power output kW | Phases | r.p.m. | Head max. m | Capacity max. l/min | Starting method | Dry weight kg without cable | Impeller passage mm |
|-----------|-------------------|---------|-----------------|--------|--------|-------------|---------------------|-----------------|-----------------------------|---------------------|
| 50TM2.4S | 1 | 50 | 0,4 | 1 | 2850 | 12,0 | 290 | condensator | 6,7 | 10 |
| 50TMA2.4S | | 50 | 0,4 | 1 | 2850 | 12,0 | 290 | condensator | 7,2 | 10 |
| 50TM2.75 | 2 | 50 | 0,75 | 3 | 2850 | 15,0 | 350 | direct | 7,8 | 10 |



| | | | |
|----------------------|----------------------------|-----------------------------|--|
| ø Discharge bore mm | | 50mm | |
| Pumping Fluid | Temperature | 0-40°C | |
| | Type of Fluid | Saltwater, Seawater | |
| Pump | Components | Impeller | Vortex impeller |
| | | Shaft Seal | Double mechanical seal |
| | | Bearings | Shielded ball bearings |
| | Material | Impeller | Glass fibre reinforced plastic |
| | | Upper casing | Glass fibre reinforced plastic |
| | | Lower casing | Glass fibre reinforced plastic |
| | Shaft Seal | Silicon carbide in oil bath | |
| Motor | Type, Poles | | Induction motor, 2 poles, IP68 |
| | Insulation | | Insulation class E |
| | Motor Protector (built-in) | | Circle thermal cut-out |
| | Lubrication | | Turbine oil (ISO VG15) |
| | Phase / Voltage | | Single phase 230V / 50Hz, 3-phase / 400V / 50Hz / d.o.l. |
| | Material | Casing | Titanium |
| Shaft | | Titanium | |
| Cable | | Rubber, 10m H07RN8-F | |
| Discharge Connection | | Inside thread, flange | |

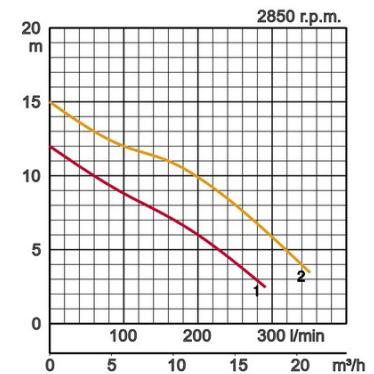

| Model | A | A1 | A2 | B | B1 | D | D1 | D2 | FL1 | FL2 | H | W1 |
|-----------|-----|-----|----|-----|----|-----|----|----|-----|-----|-----|-----|
| 50TM2.4S | 236 | 115 | 81 | 102 | 90 | 162 | 86 | 76 | - | - | 360 | 110 |
| 50TMA2.4S | 236 | 115 | 81 | 102 | - | 173 | 76 | 97 | 115 | 607 | 374 | - |
| 50TM2.75 | 236 | 115 | 81 | 102 | 90 | 162 | 86 | 76 | - | - | 374 | 110 |

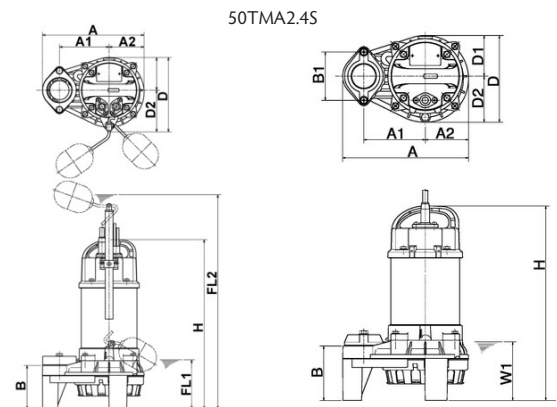

W1: lowest running water level



Specifications:

| Diameter air pipe mm | Model | Colour code curve | Power output kW | Phases | r.p.m. | Starting method | Dry weight kg without cable | Cable m |
|----------------------|-----------|-------------------|-----------------|--------|--------|-----------------|-----------------------------|---------|
| 32 | 32TRN2.75 | 1 | 0,75 | 3 | 2850 | direct | 55,0 | 10 |
| 32 | 32TRN21.5 | 2 | 1,5 | 3 | 2850 | direct | 55,0 | 10 |
| 50 | 50TRN42.2 | 3 | 2,2 | 3 | 1450 | direct | 140,0 | 10 |
| 50 | 50TRN43.7 | 4 | 3,7 | 3 | 1450 | direct | 150,0 | 10 |
| 50 | 50TRN45.5 | 5 | 5,5 | 3 | 1450 | direct | 170,0 | 10 |
| 80 | 80TRN47.5 | 6 | 7,5 | 3 | 1450 | direct | 190,0 | 10 |
| 80 | 80TRN412 | 7 | 12 | 3 | 1450 | star/delta | 200,0 | 10 |
| 80 | 80TRN417 | 8 | 17 | 3 | 1450 | star/delta | 220,0 | 20 |
| 100 | 100TRN424 | 9 | 24 | 3 | 1450 | star/delta | 435,0 | 20 |
| 150 | 150TRN440 | 10 | 40 | 3 | 1450 | star/delta | 583,0 | 20 |



**Submersible Aerators - self priming
- low maintenance - easy
installation**

Air Emission Volume - Water Depth Curve
(Air Emission Volume at 20°C)

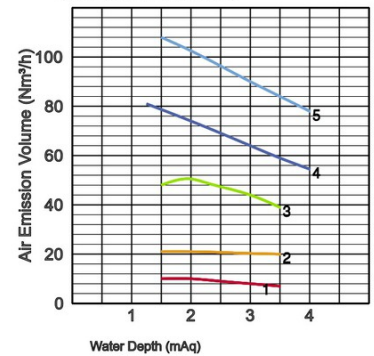

Air Emission Volume - Water Depth Curve
(Air Emission Volume at 20°C)

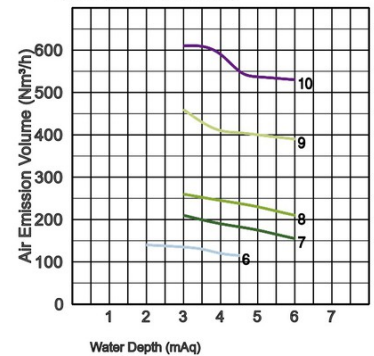

| | | | | |
|---------------------|-----------------------------|--|--|--|
| Air inlet | | 32mm, 50mm, 80mm, 100mm, 150mm | | |
| Pumping Fluid | Temperature | 0-40°C | | |
| | Type of Fluid | Municipal sewage, sewage of food industry | | |
| Pump | Components | Impeller | Vortex impeller | |
| | | Shaft Seal | Double mechanical seal | |
| | | Bearings | Shielded ball bearings | |
| | Material | Impeller | Stainless steel DIN-GX12Cr14 | |
| | | Suction Plate | Stainless steel DIN-GX12Cr14 | |
| | | Guide vane | Grey iron casting EN-GJL-200 | |
| | | Air inlet | Grey iron casting EN-GJL-200 | |
| Shaft Seal | Silicon carbide in oil bath | | | |
| Motor | Type, Poles | Induction motor, 2 poles, IP68, 4 poles | | |
| | Insulation | Insulation class F | | |
| | Phase / Voltage | 3-phase / 400V / 50Hz / d.o.l., 3-phase / 400V / 50Hz / s.d. | | |
| | Motor Protector (built-in) | Circle thermal cut-out | | |
| | Lubrication | Turbine oil (ISO VG32) | | |
| | Material | Casing | Grey iron casting EN-GJL-150, Grey iron casting EN-GJL-200 | |
| | | Shaft | Stainless steel EN-X30Cr13, Stainless steel EN-X20Cr13 | |
| Cable | | Rubber, NSSHÖU, H07RN-F | | |
| Air pipe connection | | Inside thread, flange | | |

| Model | A | A1 | B | D | D1 | H | SA | SB | SC | SD | W1 |
|-----------|-----|-----|-----|------|-----|------|-----|-----|-----|-----|-----|
| 32TRN2.75 | 371 | 184 | 146 | 420 | 90 | 473 | 180 | 116 | 175 | - | 81 |
| 32TRN21.5 | 371 | 184 | 146 | 420 | 90 | 473 | 180 | 116 | 275 | - | 81 |
| 50TRN42.2 | 660 | 271 | 226 | 700 | 140 | 689 | 230 | 154 | 370 | - | 123 |
| 50TRN43.7 | 660 | 271 | 226 | 700 | 140 | 694 | 230 | 154 | 370 | - | 123 |
| 50TRN45.5 | 660 | 271 | 226 | 700 | 140 | 835 | 230 | 154 | 370 | - | 123 |
| 80TRN47.5 | 660 | 271 | 246 | 700 | 140 | 868 | 245 | 180 | - | 585 | 133 |
| 80TRN412 | 660 | 271 | 246 | 700 | 140 | 898 | 245 | 180 | - | 585 | 133 |
| 80TRN417 | 660 | 271 | 246 | 700 | 140 | 958 | 245 | 180 | - | 585 | 133 |
| 100TRN424 | 980 | 385 | 417 | 1000 | 230 | 1225 | 345 | 256 | - | 760 | 272 |
| 150TRN440 | 980 | 410 | 452 | 1050 | 280 | 1482 | 448 | 370 | 740 | 863 | 269 |

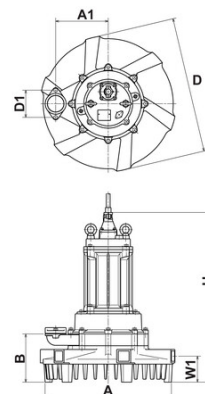



Specifications:

| Diameter air pipe mm | Model | | Colour code curve | Power output kW | Phases | r.p.m. | Starting method | tank dimensions | | | Dry weight kg without cable | | |
|----------------------|---------------|-------------------------|-------------------|-----------------|--------|--------|-----------------|-----------------|----------------|--------------|-----------------------------|-------------------------|-------|
| | free standing | with guide rail fitting | | | | | | length max. m | breadth max. m | depth max. m | free standing | with guide rail fitting | |
| 25 | 8-BER | TOS-8BER | ● | 1 | 0,75 | 3 | 2850 | direct | 3,0 | 2,0 | 4,0 | 28,0 | 23,0 |
| 32 | 15-BER | TOS-15BER | ● | 2 | 1,5 | 3 | 2850 | direct | 4,0 | 3,5 | 4,0 | 43,0 | 34,0 |
| 50 | 22-BER | TOS-22BER | ● | 3 | 2,2 | 3 | 1450 | direct | 5,0 | 5,0 | 4,5 | 75,0 | 61,0 |
| 50 | 37-BER | TOS-37BER | ● | 4 | 3,7 | 3 | 1450 | direct | 6,0 | 6,0 | 5,0 | 91,0 | 77,0 |
| 50 | 55-BER | TOS-55BER | ● | 5 | 5,5 | 3 | 1450 | direct | 7,0 | 7,0 | 6,0 | 149,0 | 132,0 |



This submersible aerator is composed of a B-type pump and an ejector (suction mechanism) so that both agitation and aeration can be carried out simultaneously. The BER aerator features extremely high oxygen dissolution efficiency and a non clog shaver mechanism.

| | | | |
|---------------------|----------------------------|---|---|
| ø Air inlet | | 25mm, 32mm, 50mm | |
| Pumping Fluid | Type of Fluid | Municipal sewage, sewage of food industry | |
| | Temperature | 0-40°C | |
| Pump | Components | Impeller | Non-clog impeller |
| | | Shaft Seal | Double mechanical seal |
| | | Bearings | Shielded ball bearings |
| | Material | Impeller | Grey iron casting EN-GJL-200 |
| | | Casing | Grey iron casting EN-GJL-200 |
| | | Suction Plate | Grey iron casting EN-GJL-200 |
| | | Diffuser | Construction steel DIN1.0040 nylon coated |
| | | Shaft Seal | Silicon carbide in oil bath |
| Motor | Phase / Voltage | | 3-phase / 400V / 50Hz / d.o.l. |
| | Motor Protector (built-in) | | Circle thermal cut-out |
| | Lubrication | | Turbine oil (ISO VG32) |
| | Insulation | | Insulation class E, Insulation class F |
| | Type, Poles | | Induction motor, 2 poles, IP68, 4 poles |
| | Material | Casing | Grey iron casting EN-GJL-150 |
| | | Shaft | Stainless steel EN-X6Cr13, Stainless steel EN-X30Cr13 |
| Cable | | Rubber, NSSHÖU | |
| Air pipe connection | | Inside thread, flange | |

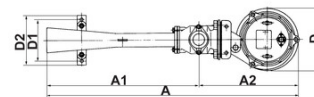
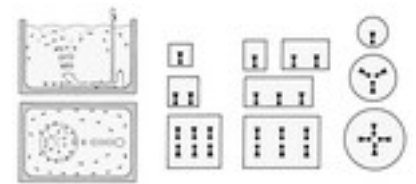
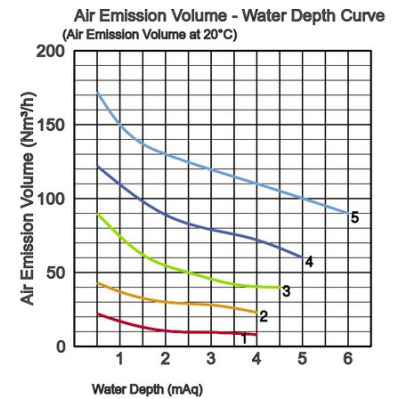

| Model | A | A1 | A2 | D | D1 | D2 | H | H1 | H2 |
|--------|------|-----|-----|-----|-----|-----|-----|-----|-----|
| 8-BER | 674 | 377 | 297 | 194 | 150 | 180 | 464 | 195 | 150 |
| 15-BER | 895 | 537 | 358 | 222 | 150 | 180 | 562 | 224 | 159 |
| 22-BER | 1158 | 687 | 471 | 317 | 220 | 260 | 679 | 312 | 232 |
| 37-BER | 1158 | 687 | 471 | 317 | 220 | 260 | 753 | 312 | 232 |
| 55-BER | 1415 | 861 | 554 | 391 | 220 | 260 | 942 | 341 | 256 |

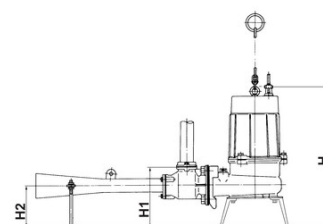



Contributing to World-wide Prosperity and Understanding through Worker- and Environment-friendly Production.

Designed for increased productivity through fully integrated streamlined production systems, Tsurumi's factory in Kyoto (Japan) features a production capacity of a full 1 million pumps per year. Large-scale modern R&D facilities offer optimum conditions for experimenting and testing of even super-large pumps and for developing new products to expand the possibilities and applications of pumps. To provide optimum conditions for our main asset, our workers, as well as for the environment, special emphasis is placed on optimized working conditions with airconditioning, minimized dust and exhaust gas emission, comprehensive recycling and waste recovery.

Tsurumi (Europe) GmbH

Wahlerstr. 10
D-40472 Düsseldorf
Tel.: +49 (0)211-4179373
Fax: +49 (0)211-417937-480
Email: sales@tsurumi.eu
www.tsurumi.eu

We reserve the right to change specifications and designs herein for improvement without prior notice. Our pumps are for professional use only. In the event that Tsurumi (Europe) GmbH have, in exceptional cases taken over, a manufacturer's warranty, this entitles the enduser to assert remedy free of charge against Tsurumi (Europe) GmbH due to any defect to the product occurring during the guarantee period (see below), also then when the warranty claims against the seller do not or no longer exist. In the event of malfunction, which is attributable to the improper handling by the enduser, no guarantee claim shall arise. Further claims shall not result from the warranty, unless if something to the contrary has explicitly been determined. The decision as to whether remedy is effected by way of replacement or repair shall be at the choice of Tsurumi (Europe) GmbH. The claims shall be time barred after a period of three months after expiry of the guarantee period, however, not before expiry of the warranty period which is valid towards the seller. In the event of doubt, the warranty period shall correspond with the warranty period which is valid between the end-user and his seller.



1SEW-EN

