



TRN 3-phase
50Hz

Aerators

Self priming submersible aerators for municipal and industrial water treatment



TRN - Submersible Aerators

Innovative Technology |

The Tsurumi TRN-submersible aerator is a submersible motor, mixer and compressor in one unit. The rotor of the submersible aerator is directly connected with the motor shaft. As shown in the illustration below, the rotation of the rotor causes a circular movement of the water, creating negative pressure around the rotor. Air is then automatically suctioned from above through the suction line. At the same time water flows in from below into the area around the rotor - this is then intensively mixed with air due to the rotation of the rotor. A fine air-water mixture is formed that is spun radially outwards at high speeds through the channels of the guide vane. The flow that this creates ensures that every part of the tank is reached and that the water is uniformly oxygenated.

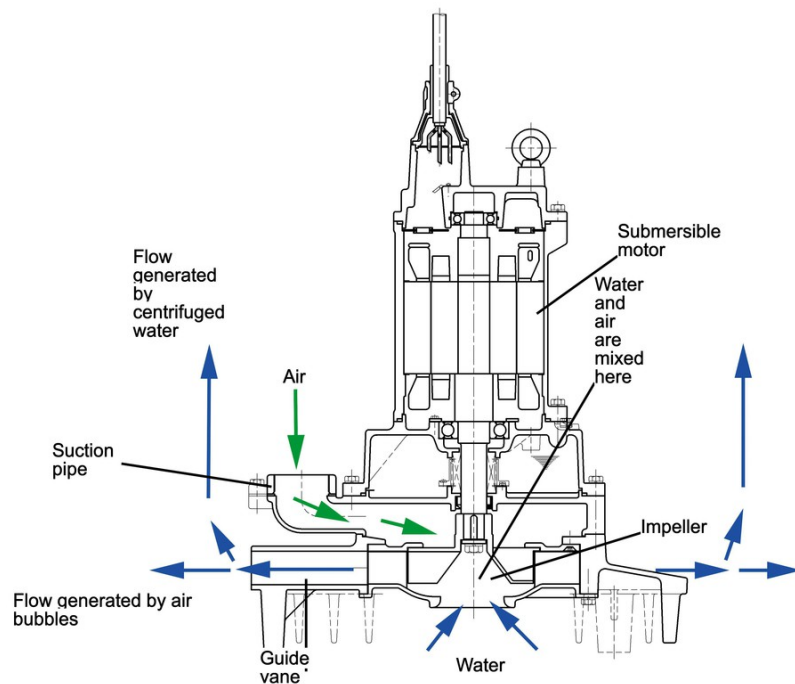

Features |

High oxygen intake

Optimum distribution and high oxygen yield thanks to high level of microscopic air bubbles.

Perfect mixing within a tank

A strong flow of water mixed with air ensures that every part of the tank is aerated and that no sediment is formed.

Simple, robust and compact

The bearings and the oil bath around the shaft seal are oversized. The air suctioned from above presses the water away from the impeller and forms an air cushion, preventing the shaft seal from touching water. This ensures fault-free 24 hour operation and ensures long product life.

Flow Sample |

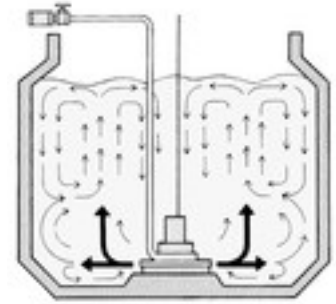

circular tank

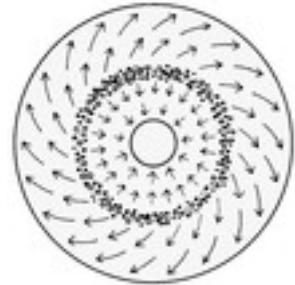

square tank

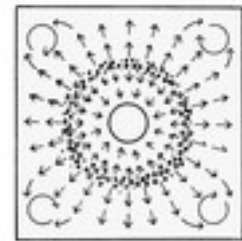

rectangular tank

ratio of tank length to width
1:1,5 or less

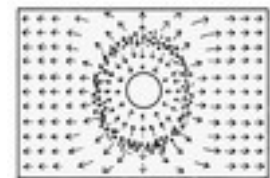

ratio of tank length to width
1:2

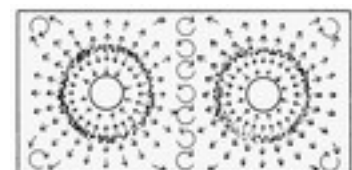

Advantages |

- thorough mixing of the waste water, thereby preventing sediments
- tiny air bubbles provide aeration with high oxygen utilisation
- completely insensitive to frost
- low noise level
- no spray formed
- simple installation and servicing thanks to simple construction
- low risk of blockage
- large oil chamber
- casing made of solid cast iron
- shaft seal is protected from water during operation
- a proven track record, with tens of thousands produced over more than 20 years

The open impeller of the TRN series sucks a large volume of water for the motor power through the pump basket. This water is then mixed with air and distributed horizontally in all directions through the channels of the guide vane.

The top of the impeller is hollow and allows the air that has been suctioned in to fill the area around the shaft seal so that it can mix with the water at the impeller. One consequence of this is that a layer of air is formed separating the shaft seal from the medium and thereby substantially increasing the life of the shaft seal. Another effect is that the water that is suctioned in is oxygenated with tiny air bubbles, effectively aerating the waste water. To prevent blockage caused by fibres and solid particles the TRN series has a special impeller and a special designed suction plate.

The long life and low maintenance of the TRN submersible aerator is due specifically to the specially selected materials. Only cast iron and stainless steel comes into contact with the water. Parts that are subject to particular wear such as the shaft, screws, the impeller and suction plate are made of stainless steel. The double mechanical seal (SiC/SiC) is a particular feature of the TRN aerator; this is cooled by an oil bath of at least 0,5l per kW motor output.

Standard accessories

- Silencer and valve set



Applications |

Mixing and equaliser tanks:

Standardising of waste water sludge loads and quantities and preventing odours developing.

SBR reactions and sludge activation tanks:

Breakdown of organic substances

Sludge stabilisation: Preventing development of odour and further oxidation of the organic components in the waste water.

Neutralisation:

Neutralisation of alkaline waste water with fumes or CO₂.

Flotation:

Flotation of oils and greases.

Pond aeration:

Improves the aeration in natural waters such as in eutrophication.





Specifications:

Diameter air pipe mm	Model	Colour code curve	Power output kW	Phases	r.p.m.	Starting method	Dry weight kg without cable	Number outlets	Rated current A	max. impeller depth m	Air volume m ³ /h	Cable m
32	32TRN2.75	1	0,75	3	2850	direct	55,0	6	2,4	3,5	7	10
32	32TRN21.5	2	1,5	3	2850	direct	55,0	6	3,5	3,5	20	10
50	50TRN42.2	3	2,2	3	1450	direct	140,0	6	5,3	3,6	39	10
50	50TRN43.7	4	3,7	3	1450	direct	150,0	6	8,6	4	55	10
50	50TRN45.5	5	5,5	3	1450	direct	170,0	6	12,0	4	78	10
80	80TRN47.5	6	7,5	3	1450	direct	190,0	6	15,9	4,5	124	10
80	80TRN412	7	12	3	1450	star/delta	200,0	6	25,7	6	157	10
80	80TRN417	8	17	3	1450	star/delta	220,0	6	35,2	6	202	20
100	100TRN424	9	24	3	1450	star/delta	435,0	8	48,0	6	388	20
150	150TRN440	10	40	3	1450	star/delta	583,0	8	80,0	6	528	20



sample:

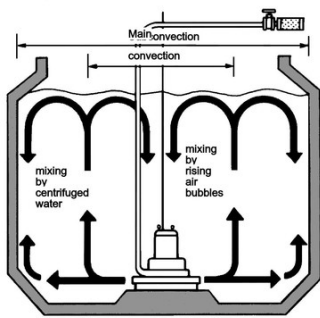

Main Convection |
direct oxygen intake thanks to air bubbles

Subconvection |
indirect oxygen intake by mixing

Air volume and oxygen intake rate measured at max. installation depth

Model	Guide vane depth	Diameter main convection	Diameter subconvection circular tank	Diameter subconvection square tank
32TRN2.75	3,5m	1,4m	3,5m	3,0m
32TRN21.5	3,5m	1,8m	4,5m	4,0m
50TRN42.2	3,6m	2,4m	6,0m	5,5m
50TRN43.7	4,0m	3,0m	7,0m	6,5m
50TRN45.5	4,0m	3,8m	9,0m	8,0m
80TRN47.5	4,5m	4,4m	10,0m	9,0m
80TRN412	6,0m	5,2m	12,0m	11,0m
80TRN417	6,0m	5,6m	13,0m	11,5m
100TRN424	6,0m	6,3m	14,5m	13,0m
150TRN440	6,0m	7,3m	17,0m	15,0m

Air Emission Volume - Water Depth Curve (Air Emission Volume at 20°C)

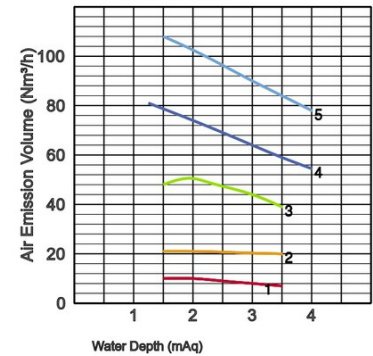

Air Emission Volume - Water Depth Curve (Air Emission Volume at 20°C)

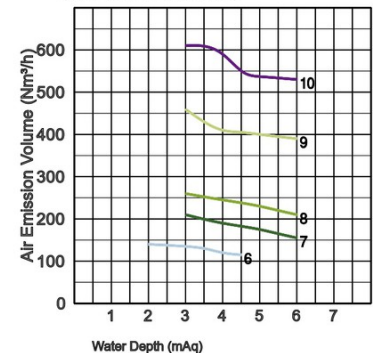

Dimensions in mm:

Model	Aerator							Air pipe	Silencer/Valve			
	A	A1	B	D	D1	H	W1		SA	SB	SC	SD
32TRN2.75	371	184	146	420	90	473	81	32	180	116	175	-
32TRN21.5	371	184	146	420	90	473	81	32	180	116	275	-
50TRN42.2	660	271	226	700	140	689	123	50	230	154	370	-
50TRN43.7	660	271	226	700	140	694	123	50	230	154	370	-
50TRN45.5	660	271	226	700	140	835	123	50	230	154	370	-
80TRN47.5	660	271	246	700	140	868	133	80	245	180	-	585
80TRN412	660	271	246	700	140	898	133	80	245	180	-	585
80TRN417	660	271	246	700	140	958	133	80	245	180	-	585
100TRN424	980	385	417	1000	230	1225	272	100	345	256	-	760
150TRN440	980	410	452	1050	280	1482	269	150	448	370	740	863

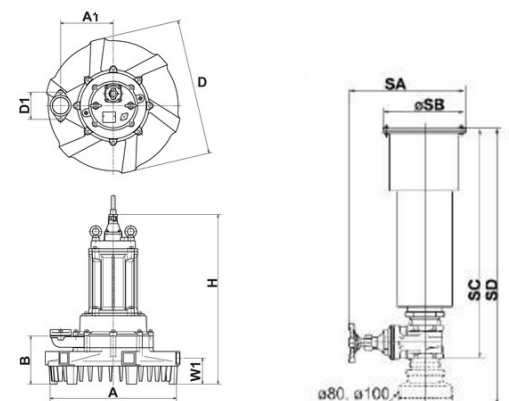

Installation types |

Free-standing installation:

The free-standing installation is the most common type of installation. The submersible aerator is placed on the floor of the tank without further anchorage. Its weight prevents the device from moving. The submersible aerator can be lifted out of the tank with a crane for servicing without having to empty the tank.

For free-standing installation a simple metal stand can be used to increase the maximum tank depth in which the submersible aerator can be installed by 0,5m without primary pressure. The inlet opening can also be extended with a pipe; the water is taken from close to the base and the air above is centrifuged. This allows the maximum tank depth to be increased by max. 1,5m.

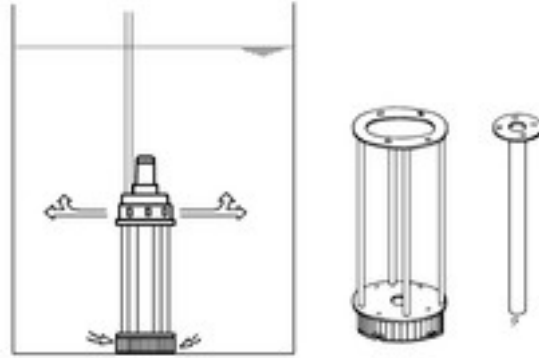

Stationary installation:

Stationary installation is generally used for fitting in deep tanks (also in combination with aeration with primary pressure, etc.) or if assembly or disassembly is not possible with a mobile crane. In this case the submersible aerators are fitted between guide pipes or on a bridge. Lifting equipment is required to lift out of the tank.

Floating installation:

Floating installation is used, for instance, to aerate unsecured tanks, ponds, lakes or rivers. The submersible aerator can also be secured oscillating on ropes or can be firmly anchored in position. Hanging installation with suitable floats is also an option. A mobile crane is generally used to lift the aerator in and out of the tank.

Installation example 32TRN2.75 |

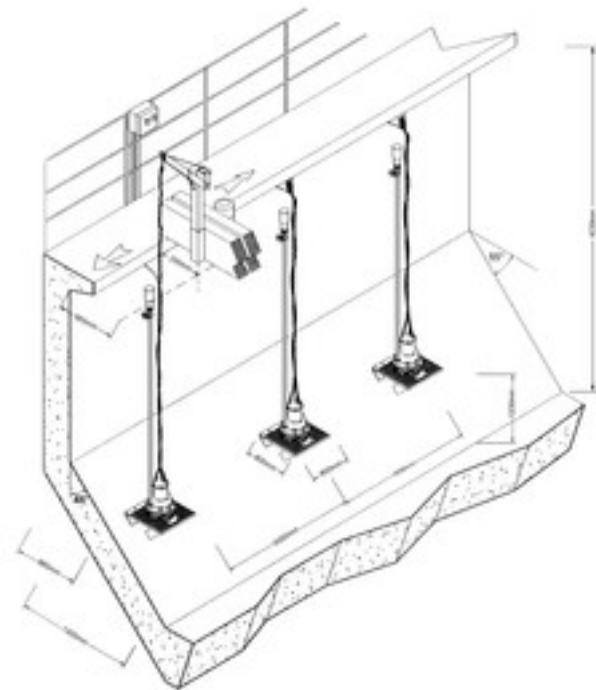

Installation example 80TRN417 |



Aeration under pre-applied pressure |

The aeration system consists of a compressor and a TRN-series TSURUMI submersible aerator.

A tank, for example is 9m, with 6m for the primary pressure of the compressor and 3m for the aerator. This system substantially reduces the necessary power input and consumption and requires much less space. The oxygen transfer rate is also increased thanks to the higher potential installation depth. This increases the time the air bubbles take to reach the surface of the water in the aeration tanks.

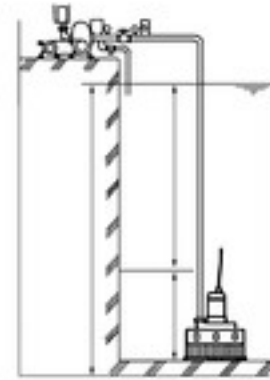

Components and material |

001	Cable	H07RN-F
018	Air inlet	GG20 (EN-GJL-200)
019	Guide vane	GG20 (EN-GJL-200)
021	Impeller	Stainless steel DIN-GX12Cr14
022	Suction plate	Stainless steel DIN-GX12Cr14
025	Mechanical seal	H-20A
026A	Spacer	Carbon steel pipe
026B	Oil sealing	VC20356
030	Oil lifter	Plastic
035	Oil plug	Stainless Steel EN-X5CrNi18-10
036	Lubricant	Turbine oil (ISO VG32)

048	Threaded flange	GG20 (EN-GJL-200)
052A	Upper bearing	6204ZZC3
052B	Lower bearing	6305ZZC3
053	Motor protector	
054	Shaft	Stainless steel EN-X30Cr13
055	Rotor	
056	Stator	
060	Bearing housing	GG15 (EN-GJL-150)
064	Motor casing	GG15 (EN-GJL-150)
072	Eye bolt	Stainless Steel EN-X5CrNi18-10

32TRN2.75 / 32TRN21.5

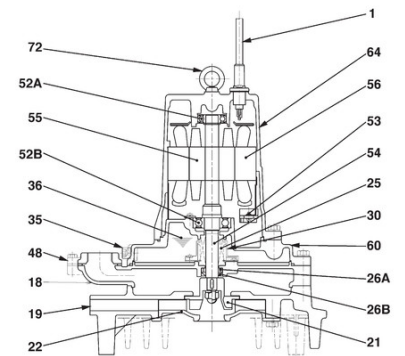

001	Cable	H07RN-F
018	Air inlet	GG20 (EN-GJL-200)
019	Guide vane	GG20 (EN-GJL-200)
021	Impeller	Stainless steel DIN-GX12Cr14
022	Suction plate	Stainless steel DIN-GX12Cr14
025	Mechanical seal	H-30A
026A	Spacer	Carbon steel pipe
026B	Oil sealing	VC30486
028	Middle plate	Stainless steel EN-X10Cr13
030	Oil lifter	Plastic
035	Oil plug	Stainless Steel EN-X5CrNi18-10

036	Lubricant	Turbine oil (ISO VG32)
048	Threaded flange	GG20 (EN-GJL-200)
052A	Upper bearing	6204ZZC3
052B	Lower bearing	6309ZZC3
053	Motor protector	
054	Shaft	Stainless steel EN-X30Cr13
055	Rotor	
056	Stator	
060	Bearing housing	GG15 (EN-GJL-150)
064	Motor casing	GG15 (EN-GJL-150)
072	Eye bolt	Stainless Steel EN-X5CrNi18-10

50TRN42.2

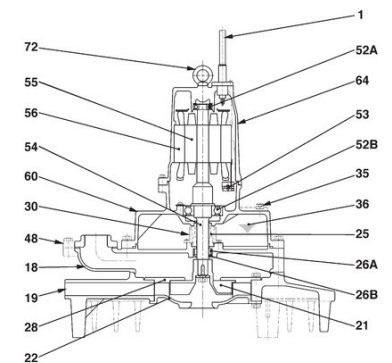

001	Cable	H07RN-F
018	Air inlet	GG20 (EN-GJL-200)
019	Guide vane	GG20 (EN-GJL-200)
021	Impeller	Stainless steel DIN-GX12Cr14
022	Suction plate	Stainless steel DIN-GX12Cr14
025	Mechanical seal	H-30A
026A	Spacer	Carbon steel pipe
026B	Oil sealing	VC30486
028	Middle plate	Stainless steel EN-X10Cr13
030	Oil lifter	Plastic
035	Oil plug	Stainless Steel EN-X5CrNi18-10

036	Lubricant	Turbine oil (ISO VG32)
048	Threaded flange	GG20 (EN-GJL-200)
052A	Upper bearing	6304ZZC3
052B	Lower bearing	6309ZZC3
053	Motor protector	
054	Shaft	Stainless steel EN-X30Cr13
055	Rotor	
056	Stator	
060	Bearing housing	GG15 (EN-GJL-150)
064	Motor casing	GG15 (EN-GJL-150)
072	Eye bolt	Stainless Steel EN-X5CrNi18-10

50TRN43.7

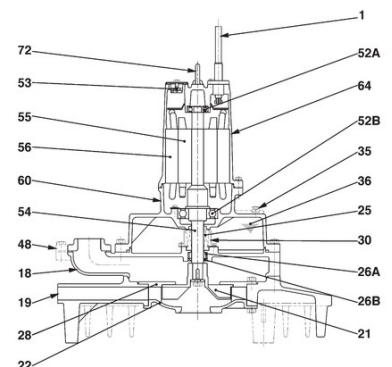

50TRN45.5 / 80TRN47.5

001	Cable	H07RN-F
006	Cable entrance	GG15 (EN-GJL-150)
018	Air inlet	GG20 (EN-GJL-200)
019	Guide vane	GG20 (EN-GJL-200)
021	Impeller	Stainless steel DIN-GX12Cr14
022	Suction plate	Stainless steel DIN-GX12Cr14
025	Mechanical seal	H-40
026A	Spacer	Carbon steel pipe
026B	Oil sealing	VC40586
028	Middle plate	Stainless steel EN-X10Cr13
030	Oil lifter	Plastic
035	Oil plug	Stainless Steel EN-X5CrNi18-10

036	Lubricant	Turbine oil (ISO VG32)
048	Threaded flange	GG20 (EN-GJL-200)
050	Motor cover	GG20 (EN-GJL-200)
052A	Upper bearing	6305ZZC3 / 6201ZZC3
052B	Lower bearing	6309ZZC3 / 6201ZZC3
053	Motor protector	
054	Shaft	Stainless steel EN-X30Cr13
055	Rotor	
056	Stator	
060	Bearing housing	GG15 (EN-GJL-150)
064	Motor casing	GG20 (EN-GJL-200)
072	Eye bolt	Stainless Steel EN-X5CrNi18-10

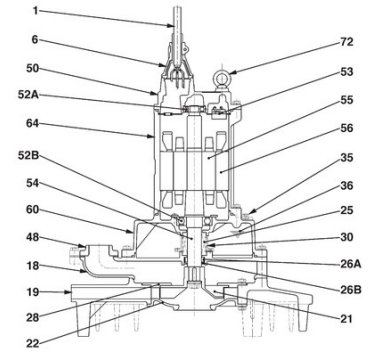

80TRN412 / 80TRN417

001	Cable	H07RN-F
006	Cable entrance	GG15 (EN-GJL-150)
018	Air inlet	GG20 (EN-GJL-200)
019	Guide vane	GG20 (EN-GJL-200)
021	Impeller	Stainless steel DIN-GX12Cr14
022	Suction plate	Stainless steel DIN-GX12Cr14
025	Mechanical seal	H-40 / H-45
026A	Spacer	Carbon steel pipe
026B	Oil sealing	VC40586 / VC45686
028	Middle plate	Stainless steel EN-X10Cr13 / Stainless steel DIN-GX12Cr14
030	Oil lifter	Plastic
035	Oil plug	Stainless Steel EN-X5CrNi18-10

036	Lubricant	Turbine oil (ISO VG32)
048	Threaded flange	GG20 (EN-GJL-200)
050	Motor cover	GG20 (EN-GJL-200)
052A	Upper bearing	6306ZZC3
052B	Lower bearing	6310ZZC3
053	Miniature protector	
054	Shaft	Stainless steel EN-X30Cr13
055	Rotor	
056	Stator	
060	Bearing housing	GG15 (EN-GJL-150)
064	Motor casing	GG20 (EN-GJL-200)
072	Eye bolt	Stainless Steel EN-X5CrNi18-10

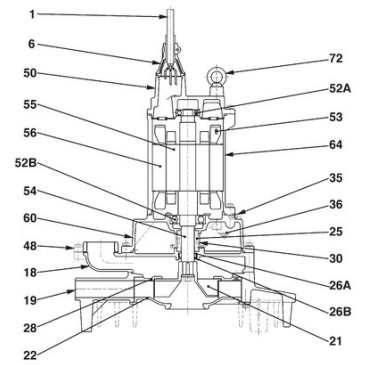

100TRN424

001	Cable	H07RN-F
006	Cable entrance	GG15 (EN-GJL-150)
018	Air inlet	GG20 (EN-GJL-200)
019	Guide vane	GG20 (EN-GJL-200)
021	Impeller	Stainless steel DIN-GX12Cr14
022	Suction plate	Stainless steel DIN-GX12Cr14
023	Strainer	DIN1.0040, stainless EN-X5CrNi18-10
025	Mechanical seal	H-45
026A	Spacer	Carbon steel pipe
026B	Oil sealing	VC45686
028	Middle plate	Stainless steel DIN-GX12Cr14
030	Oil lifter	Plastic
035	Oil plug	Stainless Steel EN-X5CrNi18-10

036	Lubricant	Turbine oil (ISO VG32)
048	Threaded flange	GG20 (EN-GJL-200)
050	Motor cover	GG20 (EN-GJL-200)
052A	Upper bearing	6309ZZC3
052B	Lower bearing	6312ZZC3
053	Miniature protector	
054	Shaft	Stainless steel EN-X20Cr13
055	Rotor	
056	Stator	
060	Bearing housing	GG15 (EN-GJL-150)
064	Motor casing	GG20 (EN-GJL-200)
072	Eye bolt	Stainless Steel EN-X5CrNi18-10

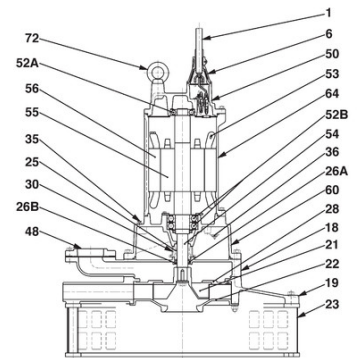

150TRN440

001	Cable	H07RN-F
003	Gland	GG20 (EN-GJL-200)
006	Cable entrance	GG20 (EN-GJL-200)
018	Air inlet	GG20 (EN-GJL-200)
019	Guide vane	GG20 (EN-GJL-200)
021	Impeller	Stainless steel DIN-GX12Cr14
022	Suction plate	Stainless steel DIN-GX12Cr14
023	Strainer	DIN1.0040, stainless EN-X5CrNi18-10
025	Mechanical seal	H-60
026	Oil sealing	SC709513
028	Middle plate	Stainless steel DIN-GX12Cr14
030	Oil lifter	Plastic
035A	Oil plug	Stainless Steel EN-X5CrNi18-10

035B	Oil plug	Stainless Steel EN-X5CrNi18-10
036	Lubricant	Turbine oil (ISO VG32)
048	Threaded flange	GG20 (EN-GJL-200)
050	Motor cover	GG20 (EN-GJL-200)
052A	Upper bearing	6310ZZC3
052B	Lower bearing	6314ZZC3
053	Miniature protector	
054	Shaft	Stainless steel EN-X20Cr13
055	Rotor	
056	Stator	
060	Bearing housing	GG20 (EN-GJL-200)
064	Motor casing	GG20 (EN-GJL-200)
072	Eye bolt	Stainless Steel EN-X5CrNi18-10

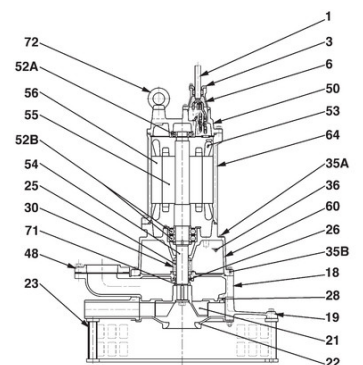



Contributing to World-wide Prosperity and Understanding through Worker- and Environment-friendly Production.

Designed for increased productivity through fully integrated streamlined production systems, Tsurumi's factory in Kyoto (Japan) features a production capacity of a full 1 million pumps per year. Large-scale modern R&D facilities offer optimum conditions for experimenting and testing of even super-large pumps and for developing new products to expand the possibilities and applications of pumps. To provide optimum conditions for our main asset, our workers, as well as for the environment, special emphasis is placed on optimized working conditions with airconditioning, minimized dust and exhaust gas emission, comprehensive recycling and waste recovery.

Tsurumi (Europe) GmbH

Wahlerstr. 10
D-40472 Düsseldorf
Tel.: +49 (0)211-4179373
Fax: +49 (0)211-417937-480
Email: sales@tsurumi.eu
www.tsurumi.eu

We reserve the right to change specifications and designs herein for improvement without prior notice. Our pumps are for professional use only. In the event that Tsurumi (Europe) GmbH have, in exceptional cases taken over, a manufacturer's warranty, this entitles the enduser to assert remedy free of charge against Tsurumi (Europe) GmbH due to any defect to the product occurring during the guarantee period (see below), also then when the warranty claims against the seller do not or no longer exist. In the event of malfunction, which is attributable to the improper handling by the enduser, no guarantee claim shall arise. Further claims shall not result from the warranty, unless if something to the contrary has explicitly been determined. The decision as to whether remedy is effected by way of replacement or repair shall be at the choice of Tsurumi (Europe) GmbH. The claims shall be time barred after a period of three months after expiry of the guarantee period, however, not before expiry of the warranty period which is valid towards the seller. In the event of doubt, the warranty period shall correspond with the warranty period which is valid between the end-user and his seller.



sew-TRN-EN

