



**SFQ** 3-phase  
50Hz

Stainless steel pump

The SFQ pump has been developed exclusively for corrosive liquids. Applying austenitic steel in all wetted parts, the SFQ pump is a highly specialised pump in terms of design and materials.





## Vortex Impeller

This impeller is used mainly to avoid clogging or wear by large or stringy solids in the water. It accelerates part of the water to great speed, and this speed is used to smoothly move all the water from inlet to outlet.

### Optional Accessories 5,5kW and above:

- Guide rail fitting consisting of:
  - Guide support / Guide hook
  - Duck foot bend
  - Lifting chain



## Specifications:

Model		Colour code curve	Bore mm	Power output kW	Phases	r.p.m.	Head max. m	Capacity max. l/min	Starting method	Dry weight kg without cable		Impeller passage mm
free standing	with guide rail fitting									free standing	with guide rail fitting	
80SFQ21.5	-	1	80	1,5	3	2850	20,9	645	direct	36,0	-	6
80SFQ23.7	-	2	80	3,7	3	2850	24,6	1180	direct	52,0	-	15
80SFQ27.5	TOS80SFQ27.5	3	80	7,5	3	2850	34,8	2000	direct	123,0	112,0	30
80SFQ211	TOS80SFQ211	4	80	11	3	2850	44,0	1940	star/delta	143,0	132,0	30

ø Discharge bore mm		80mm		
Pumping Fluid	Type of Fluid	Aggressive sewage		
	Temperature	0-40°C		
Pump	Components	Impeller	Open type impeller	
		Shaft Seal	Double mechanical seal	
		Bearings	Shielded ball bearings	
	Material	Impeller	Stainless steel casting DIN X5CrNiMo17-12-2, Stainless steel casting DIN GX5CrNiMo19-11-2	
		Casing	Stainless steel casting DIN X5CrNiMo17-12-2, Stainless steel casting DIN GX5CrNiMo19-11-2	
		Suction Plate	Stainless steel casting DIN X5CrNiMo17-12-2, Stainless steel casting DIN GX5CrNiMo19-11-2	
	Shaft Seal	Silicon carbide in oil bath		
Motor	Insulation		Insulation class F	
	Lubrication		Turbine oil (ISO VG32)	
	Type, Poles		Induction motor, 2 poles, IP68	
	Motor Protector (built-in)		Circle thermal cut-out	
	Phase / Voltage		3-phase / 400V / 50Hz / d.o.l., 3-phase / 400V / 50Hz / s.d.	
	Material	Casing	Stainless steel casting DIN X5CrNiMo17-12-2, Stainless steel casting DIN GX5CrNiMo19-11-2	
Shaft		Stainless steel EN-X5CrNiMo17-12-2		
Cable		Rubber, NSSHÖU		
Discharge Connection		Inside thread, JIS10K flange		

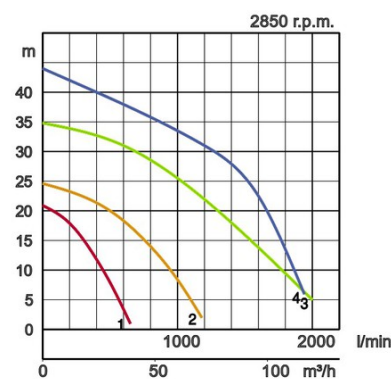

## Dimensions in mm:

Model	A	A1	A2	A3	B	D	D1	D2	H	W1	W2
80SFQ21.5	329	165	110	-	109	221	110	111	484	95	415
80SFQ23.7	359	180	125	-	154	257	125	132	542	130	495
80SFQ27.5	635	362	180	250	287	360	180	180	844	190	690
80SFQ211	635	362	180	250	287	360	180	180	892	190	710

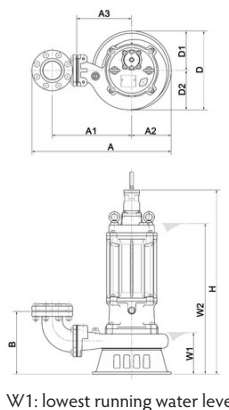

Dimensions - guide rail fitting type in mm:

Model	A	A1	A2	A3	A5	A6	D	D1	D2	H	H1	H2	M1	M2	W1	W2
80SFQ21.5	-	-	-	-	-	-	-	-	-	-	-	-	-	-	-	-
80SFQ23.7	-	-	-	-	-	-	-	-	-	-	-	-	-	-	-	-
80SFQ27.5	550	370	180	310	165	258	360	180	180	875	1067	31	600	500	220	720
80SFQ211	550	370	180	310	165	258	360	180	180	923	1111	31	600	500	220	745

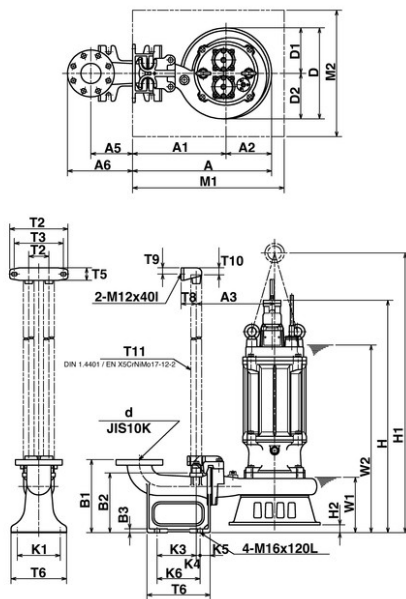

W1: lowest running water level

Dischcharge bore mmd	T2	T3	T4	T5	T6	T7	T8	T9	T10	T11	K1	K3	K4	K5	K6	B1	B2	B3	
80mm	80	230	195	80	50	220	250	60	25	28	32	170	155	15	40	170	290	237	15

# Tsurumi (Europe) GmbH

Wahlerstr. 10  
 D-40472 Düsseldorf  
 Tel.: +49 (0)211-4179373  
 Fax: +49 (0)211-417937-480  
 Email: sales@tsurumi.eu  
 www.tsurumi.eu

We reserve the right to change specifications and designs herein for improvement without prior notice. Our pumps are for professional use only. In the event that Tsurumi (Europe) GmbH have, in exceptional cases taken over, a manufacturer's warranty, this entitles the enduser to assert remedy free of charge against Tsurumi (Europe) GmbH due to any defect to the product occurring during the guarantee period (see below), also then when the warranty claims against the seller do not or no longer exist. In the event of malfunction, which is attributable to the improper handling by the enduser, no guarantee claim shall arise. Further claims shall not result from the warranty, unless if something to the contrary has explicitly been determined. The decision as to whether remedy is effected by way of replacement or repair shall be at the choice of Tsurumi (Europe) GmbH. The claims shall be time barred after a period of three months after expiry of the guarantee period, however, not before expiry of the warranty period which is valid towards the seller. In the event of doubt, the warranty period shall correspond with the warranty period which is valid between the end-user and his seller.

sew-SFO-EN

